



Internal Technical Report

Four Channel Correlated Noise Source with Variable Correlation Coefficient

D. Anish Roshi, A. Praveenkumar and M. Gopinathan

Date: 03-01-2000

1 Introduction

The basic measurement made in a radio interferometer (like the GMRT) is the cross correlation of signals from different antennas. The hardware unit which performs the correlation is called a correlator. Since the system noise (receiver + ground spillover + "resolved" sky background) of different antennas are independent, observation on a source produce a correlation coefficient less than unity. Typically for astronomical sources the correlation coefficient varies over 3×10^{-3} to 0.4 in the frequency band of the GMRT. To test the GMRT correlator, we designed and built a correlated noise source with correlation coefficient varying in this range. From practical considerations, the number of outputs is restricted to four. Provision to feed an external correlated signal (for example a sine wave) also exists.

2 Principle of operation

Consider two signals v_1 and v_2 . Let a common signal v_c be added to the two signals. The correlation coefficient of the two signal is defined as

$$\rho = \frac{\langle (v_1 + v_c) \times (v_2 + v_c)^* \rangle}{\sqrt{\langle (v_1 + v_c)^2 \rangle \langle (v_2 + v_c)^2 \rangle}} \quad (1)$$

where the angle brackets indicate time average. If v_1 , v_2 and v_c are independent Gaussian random noise then the above equation becomes

$$\rho = \frac{\langle v_c^2 \rangle}{\sqrt{(\langle v_1^2 \rangle + \langle v_c^2 \rangle)(\langle v_2^2 \rangle + \langle v_c^2 \rangle)}} \quad (2)$$

Let P_1 , P_2 and P_c are the powers of noise v_1 , v_2 and v_c respectively and let $P_1 = P_2 = P$, then

$$\rho = \frac{P_c}{P + P_c} \quad (3)$$

The above equation shows that a variable correlation coefficient between two noise sources can be obtained by adding the noise power from a third source (P_c) and varying its power.

3 Block diagram

The basic block diagram of the designed system is given in Fig. 1. It consists of four independent noise sources and one common noise source all realized using reverse biased zener diodes. Compared with avalanche solid state noise diode, Zener diode offers a simple and low cost method of generating the noise. Moreover, in our application the bandwidth needed is not large (< 16 MHz) and "flat" spectral density over this bandwidth is not required (~ 3 dB). The output of the common noise source is fed to a four way power splitter and combined with the outputs of the four independent noise sources. The amplitude of the common noise source is controlled using a variable attenuator (0 to 15 dB and an external 10 dB fixed attenuator). In addition to this, the common noise source alone can be switched off. An external input can also be combined with all the four noise sources. Automatic level control (ALC) circuits (old GMRT ALC circuit) are introduced at the four outputs to maintain the power level to 0 dBm as required by the correlator. The output power can be further adjusted using a 0/2dB attenuator. The output bandwidth is restricted to 12 MHz using elliptic low pass filters.

4 Circuit Schematic

The schematic of the circuit is shown in Fig 2a,b. The noise generated by the zener diode is amplified using operational amplifier AD5539. The operational amplifiers are also configured to add the signal from the external input to the common noise source as well as to add the common noise to the four independent noise sources. The noise bandwidth is restricted to 12 MHz using elliptic low pass filters. A home made 4 way power splitter is used to divide the common noise source power for combining with the four independent noise sources. A 0/2 dB attenuator is implemented using reflective type GaAs FET MMIC switches (SW239).

5 System Characteristics

Fig. 3 shows the spectra at points (A) and (B) (marked in Fig. 1). For these measurements a 12 dB fixed attenuator was used. The output power spectra measured with a spectrum analyzer when the attenuator values are changed between 0 dB and 15 dB and also when the common noise source is switched off are shown in Fig. 4. Spectra of all the four outputs are shown in the same plot. The output power variation is about 3 dB.

The following measurements are made with 10 "good" multipliers of the GMRT correlator. The four channels of the noise source are connected to sampler inputs C00 to C03. The variation of correlation coefficient for different attenuator values is plotted in Fig. 5 for a narrow bandwidth of 125 KHz about 10 MHz. For these measurements a 10 dB external fixed attenuator is used along with the variable attenuator. The self spectra of all the four outputs are shown in Fig. 6. Fig. 7 and 8 are the 6 cross spectra obtained for 0 dB and 7 dB variable attenuator values. The cross coupling between the four outputs when the common noise source is switched off is shown in Fig. 9. The cross coupling measurements for channels 1, 2 and 3 are limited by the inherent coupling in the correlator. This limitation is checked

using two independent noise sources. Please note that channel 4 of the system seem to have higher cross coupling, especially with channel 3.

6 Acknowledgment

We thank T. L. Venkatasubramani and Ajith Kumar for providing tested old GMRT AI PCBs and circuits.

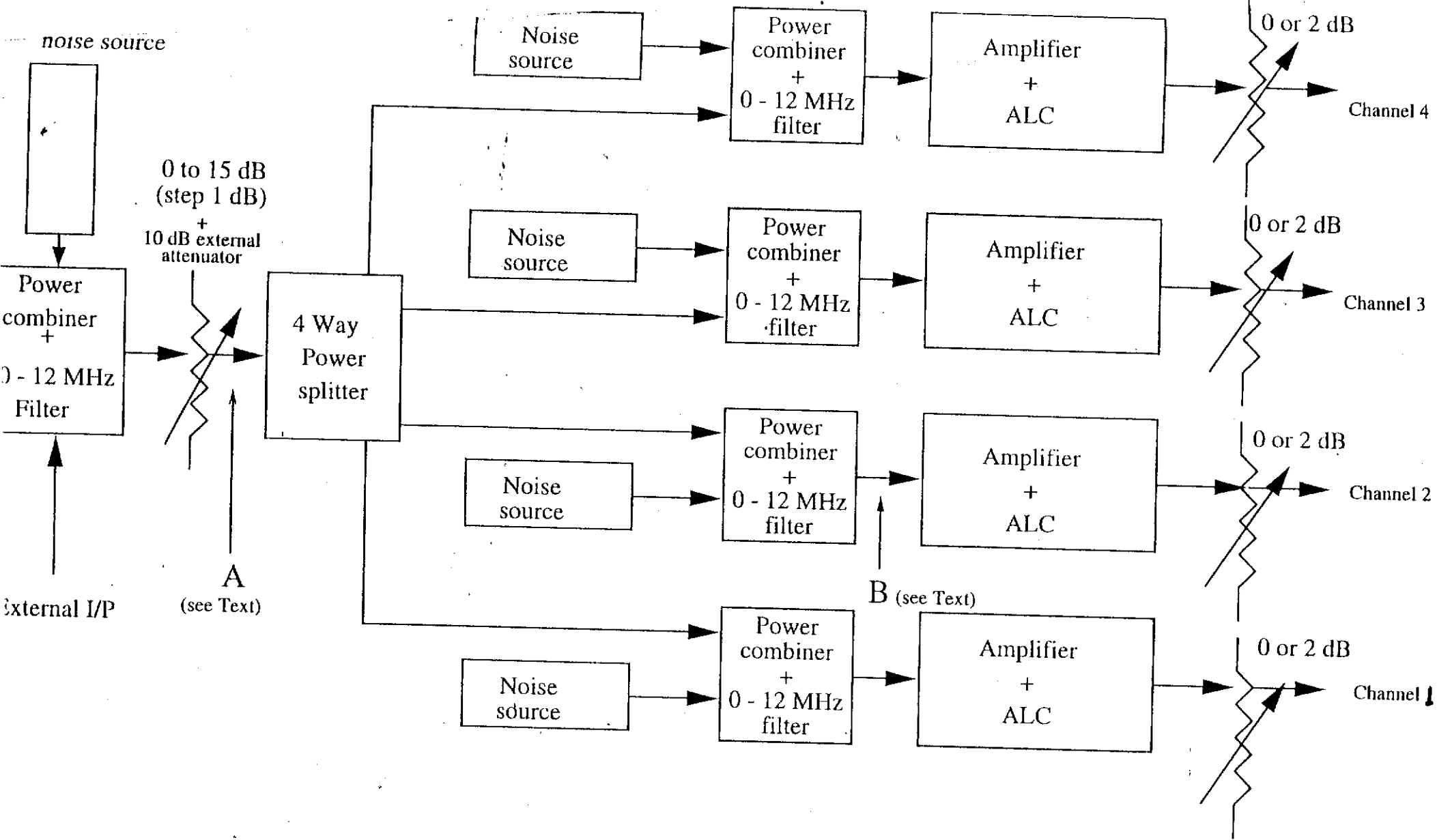
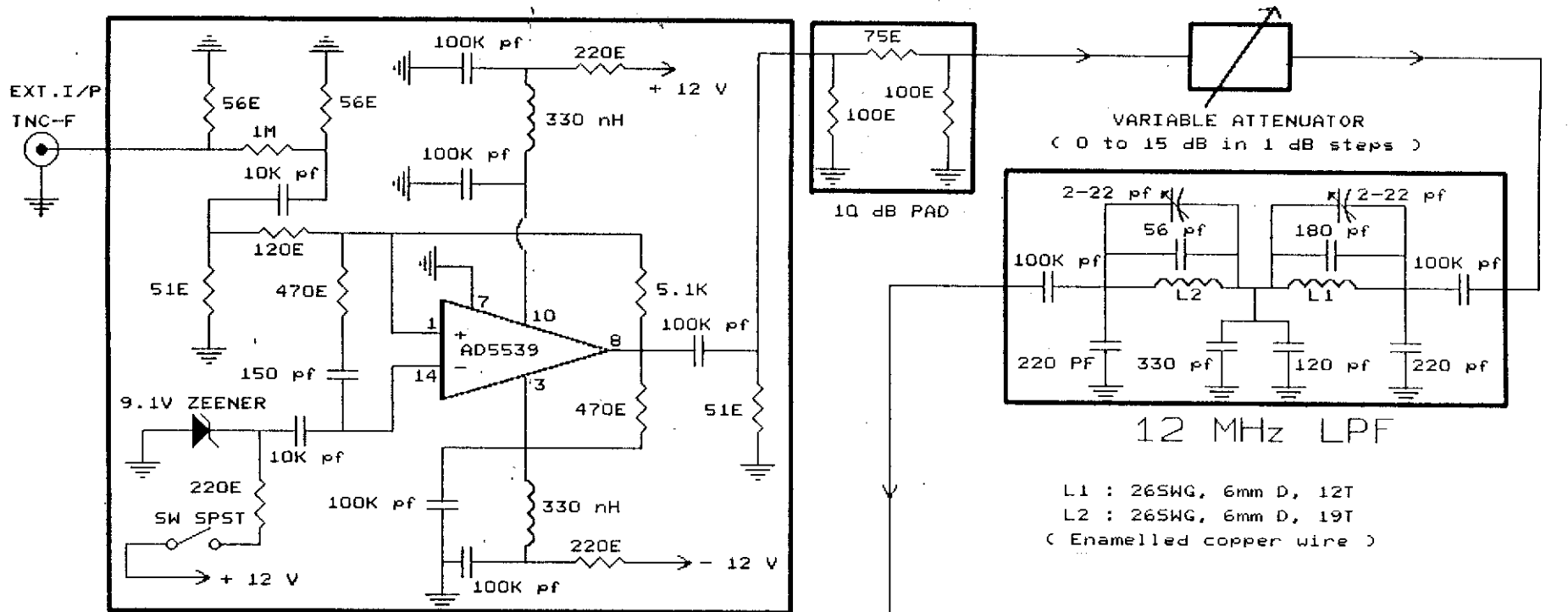

Fig 1: Four Channel Correlated Noise Source



COMMON NOISE SOURCE + AMPLIFIER

T1 to T4 : Toroidal Transformers
 T1 : 24 T, 25 twists/"
 T2, T3, T4 : 15 T, 25 twist/"

All toroids wound with 32 SWG enamelled copper wire

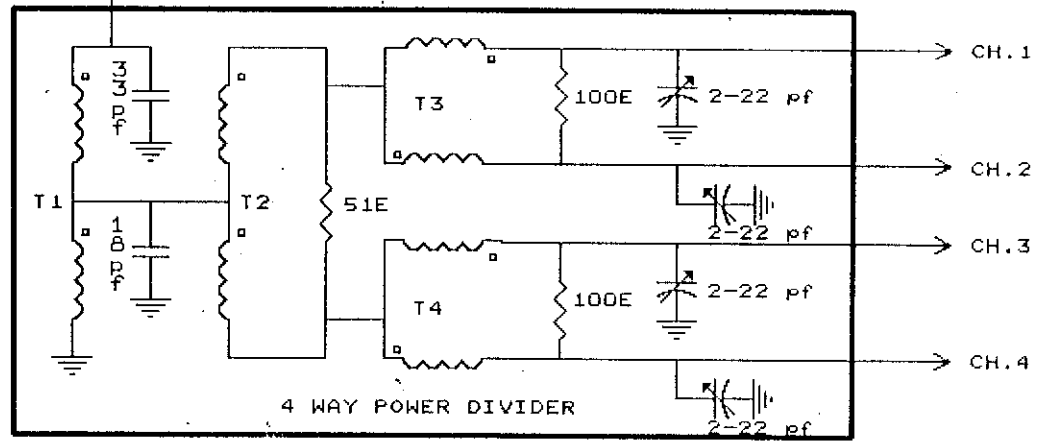

TO NOISE SOURCE + AMPLIFIER UNITS

Fig. 2a : 4 CHANNEL CORRELATED NOISE SOURCE.

NOISE SOURCE + AMPLIFIER

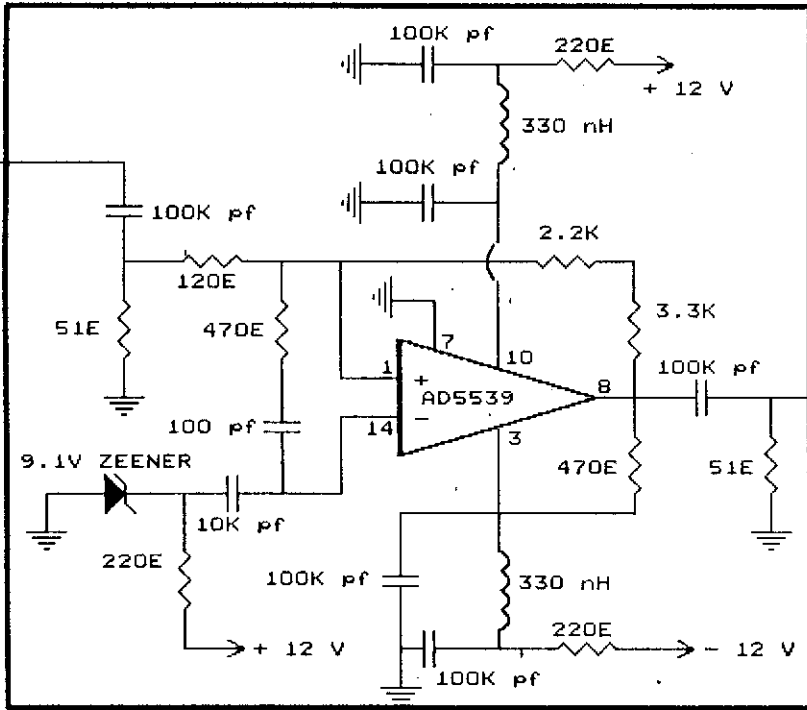

DC Power Supply Requirement

- + 12 V/ 2A
- 12 V/ 2A
- 07 V/100mA

12 MHz LPF

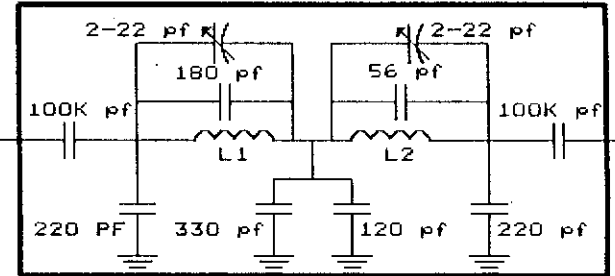

L1 : 26SWG, 6mm D, 12T

L2 : 26SWG, 6mm D, 19T

(Enamelled copper wire)

4 CHANNEL CORRELATED NOISE SOURCE

CH. 1

CH. 2
CH. 3
CH. 4

SAME AS CH. 1
CIRCUITRY

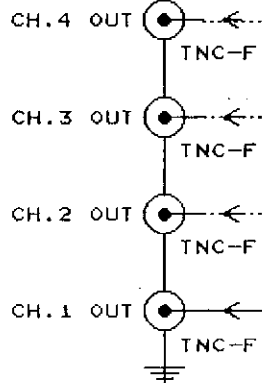

2 dB ATTEN.
(selectable)

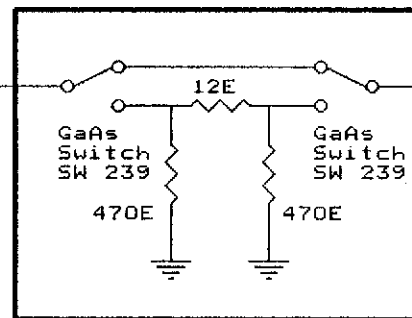

Drawn By M.Gopinathan
23-12-99

4 CHANNEL CORRELATED NOISE SOURCE.

Spectra at Point (A) and (B) (shown in Fig 1) measured with a Spectrum Analyzer

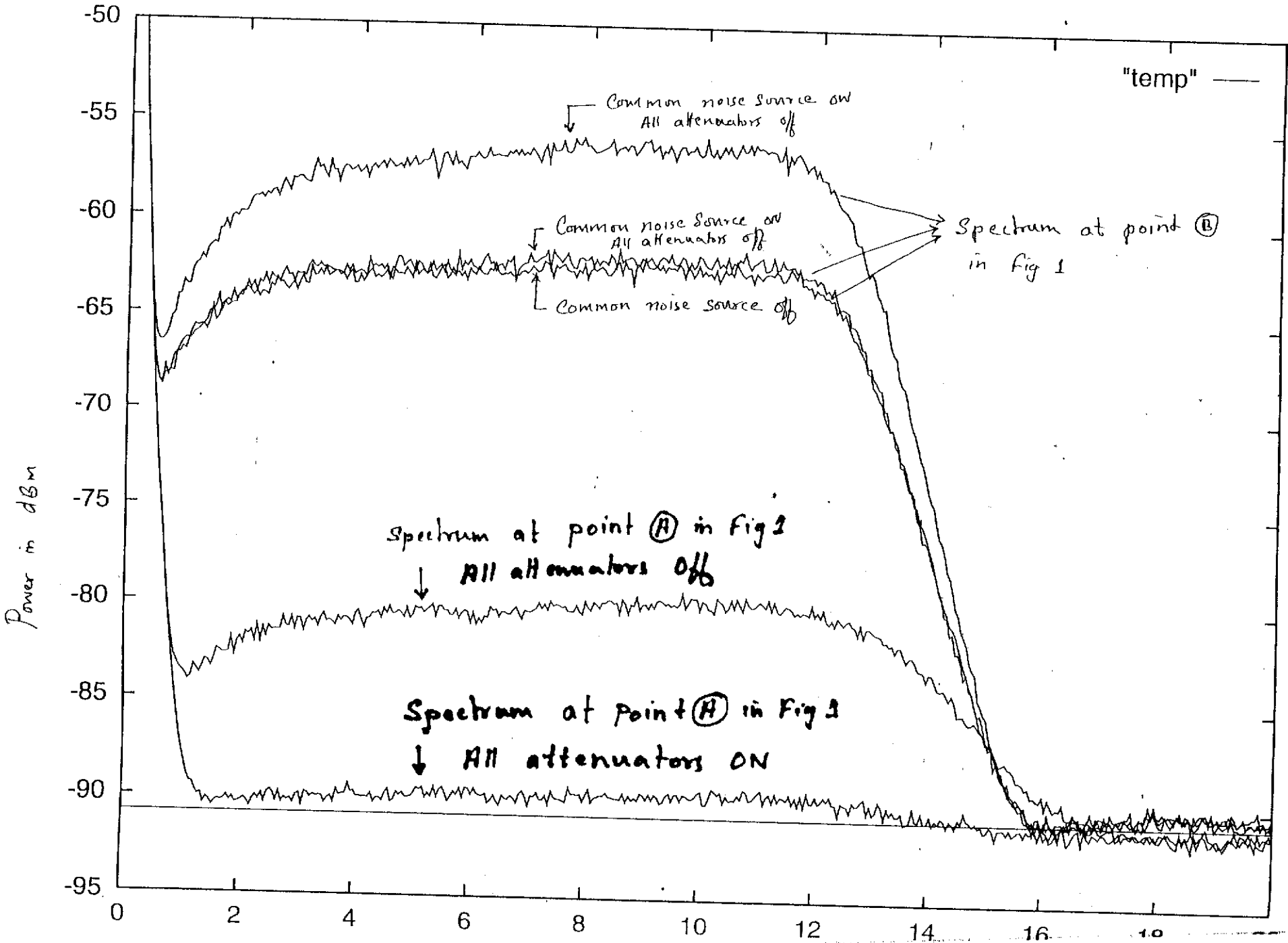

The external fixed attenuator value was 12 dB for these plots

Spectrum Analyzer Settings
 Res BW = 100 kHz
 VBW = 10 kHz
 Span 0 - 20 MHz

Fig 3

Output spectra of all 4 channels ~~are~~ showing the power variation when
Attenuators are varied ~~from~~ ^{between} 0dB to 15dB.

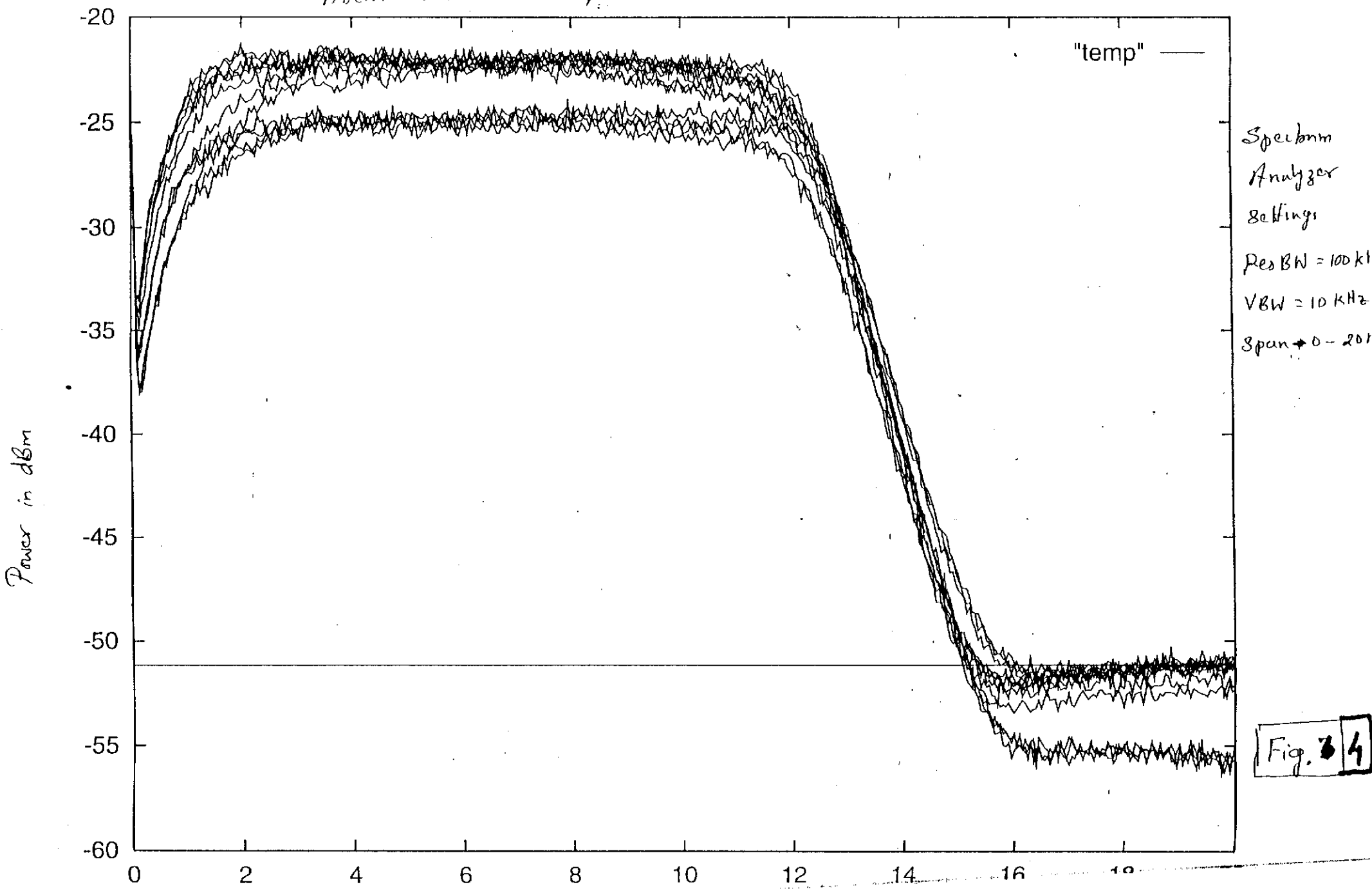

Fig. 34

Common noise source off



15dB 14dB 13dB 12dB 11dB 10dB 9dB 8dB 7dB 6dB 5dB 4dB 3dB 2dB 1dB 0dB

Correlation Coefficient

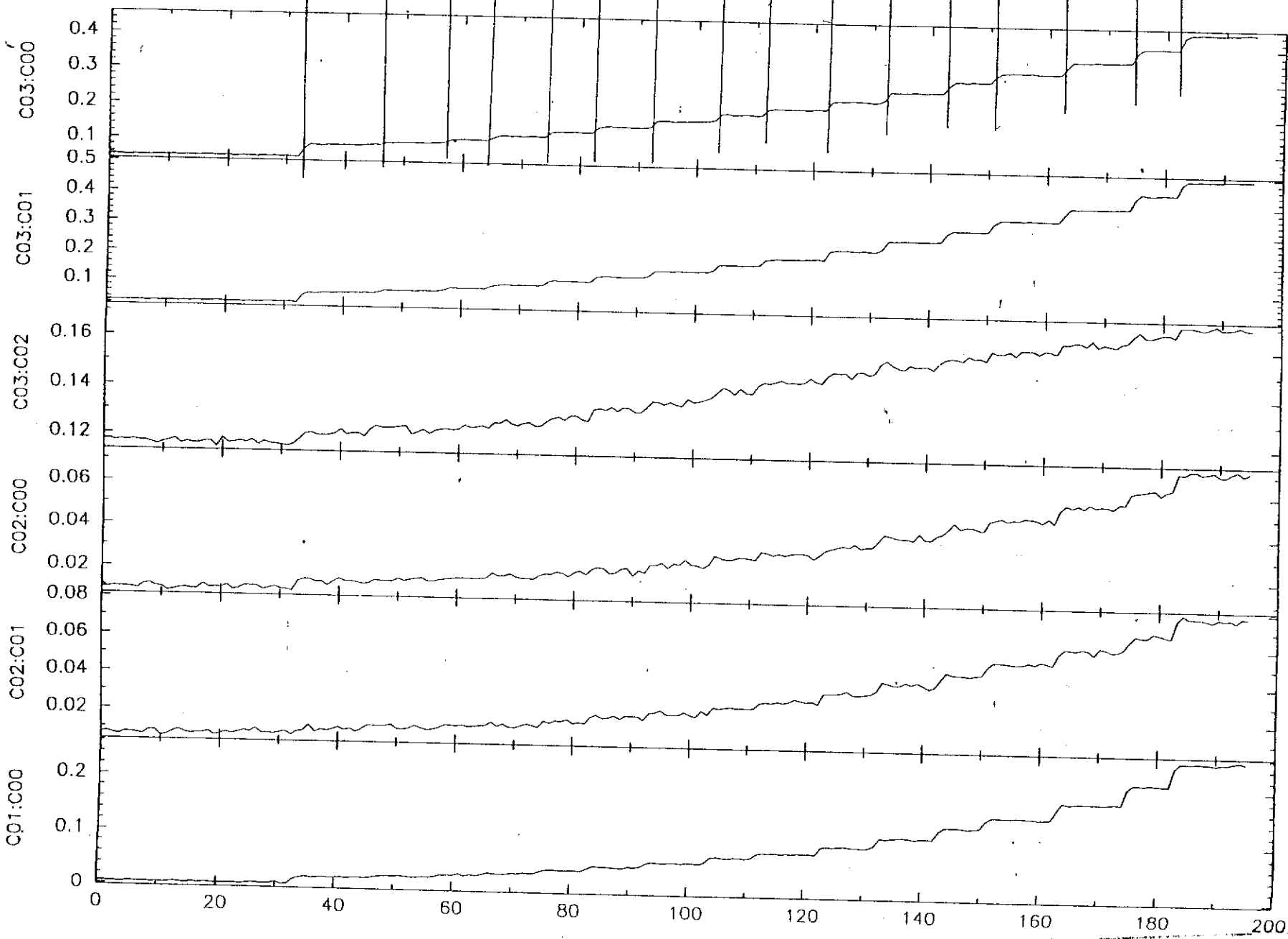

With 10dB external fixed attenuator

- C00 = channel 1
- C01 = channel 2
- C02 = channel 3
- C03 = channel 4

For this plot Spectral channel 80 was taken. This corresponds to 10MHz and band width 12.5kHz

Fig. 5

Proportional to
Counts \propto d.p. power

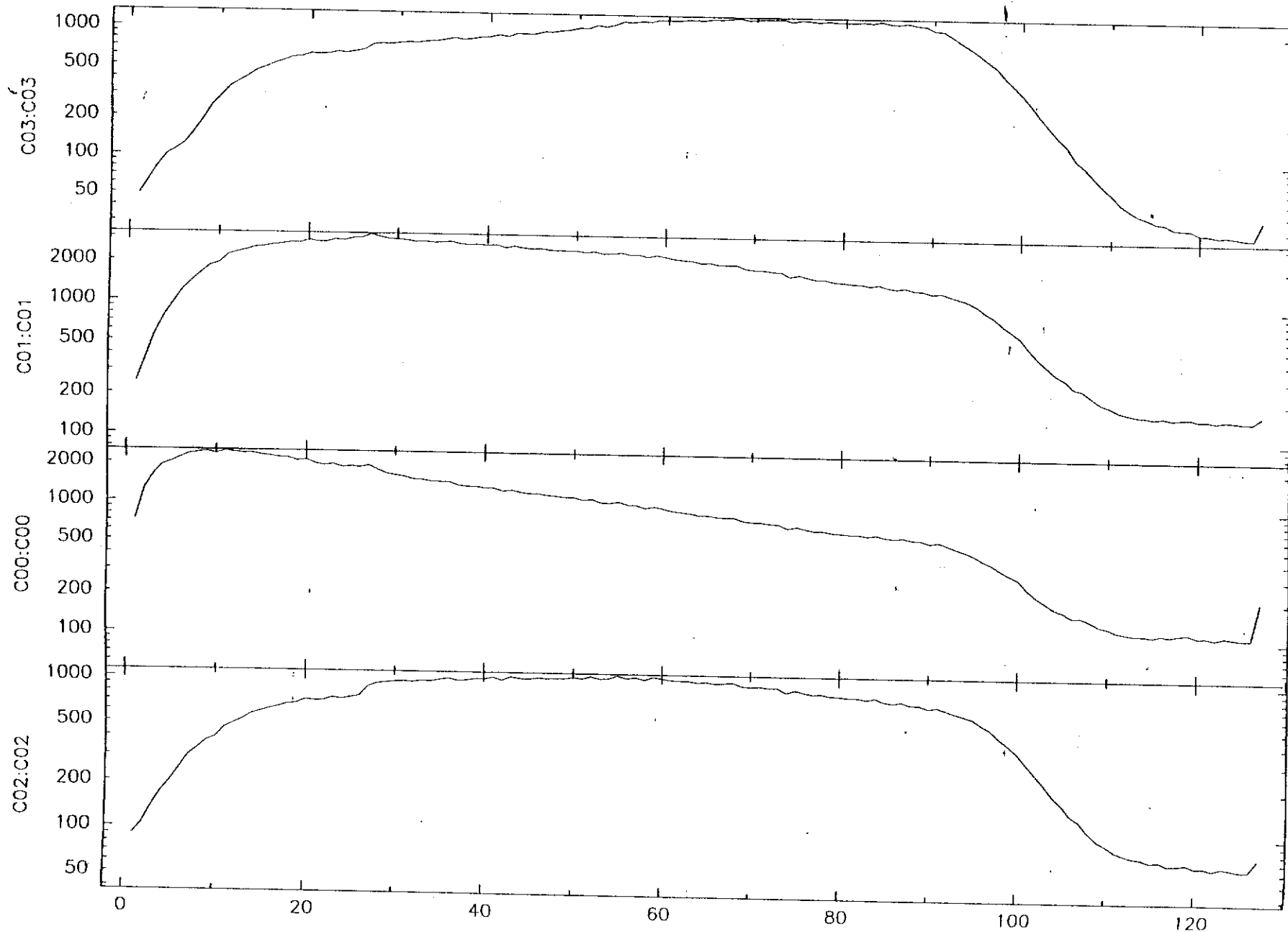

C00 - channel 1
C01 - channel 2
C02 - channel 3
C03 - channel 4

Fig 5

Channel number [frequency range 0 to 12 MHz]

Cross power spectrum for attenuation value 0 dB, +10dB fixed attenuator
 ~~~~~  
 ↑  
 variable

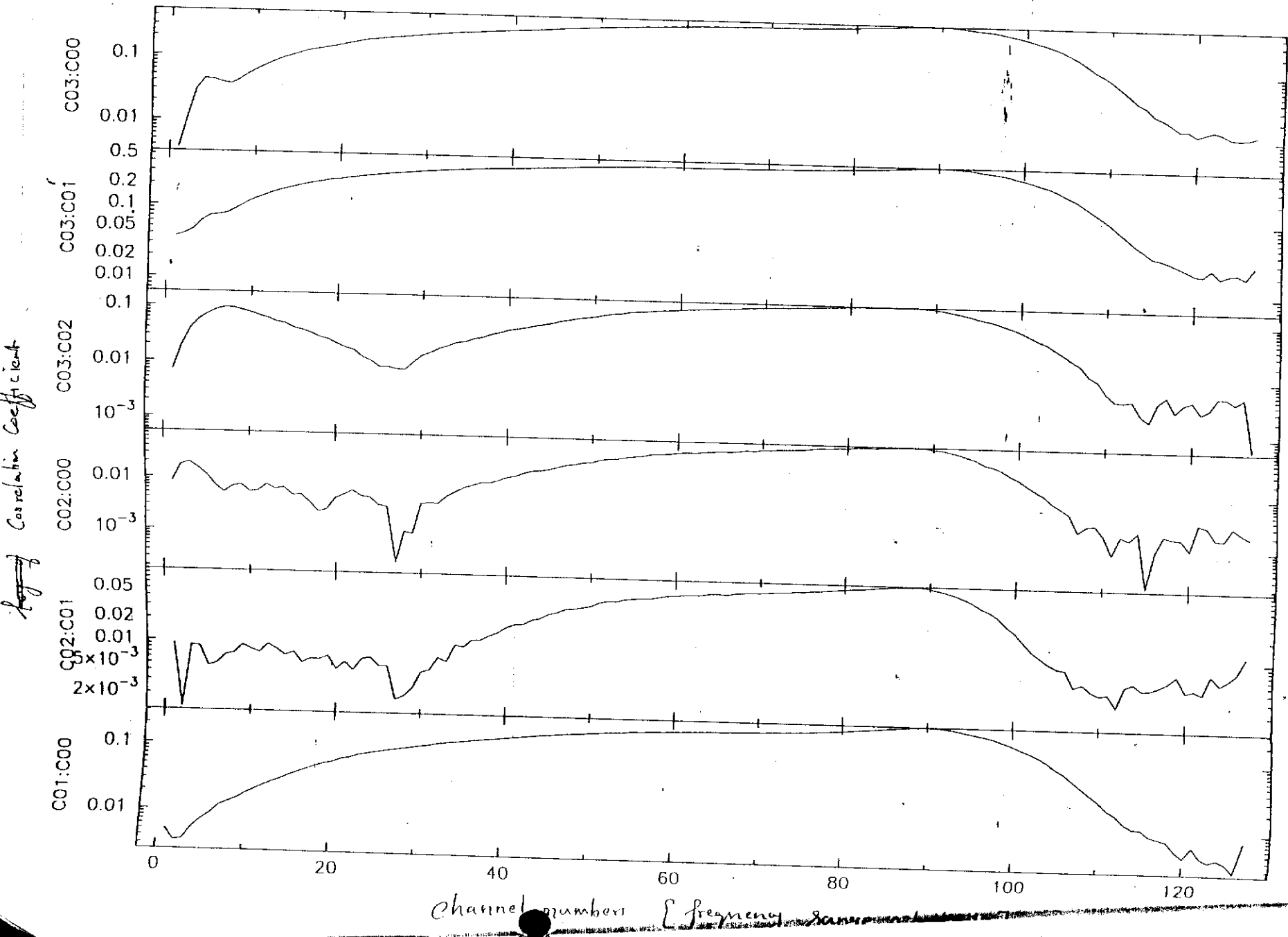

C00 - channel 1  
 C01 - channel 2  
 C02 - channel 3  
 C03 - channel 4

Fig 7

Cross power Spectrum for attenuation value 7dB + 10dB fixed & attenuator  
 Variable

of Correlation Coefficient

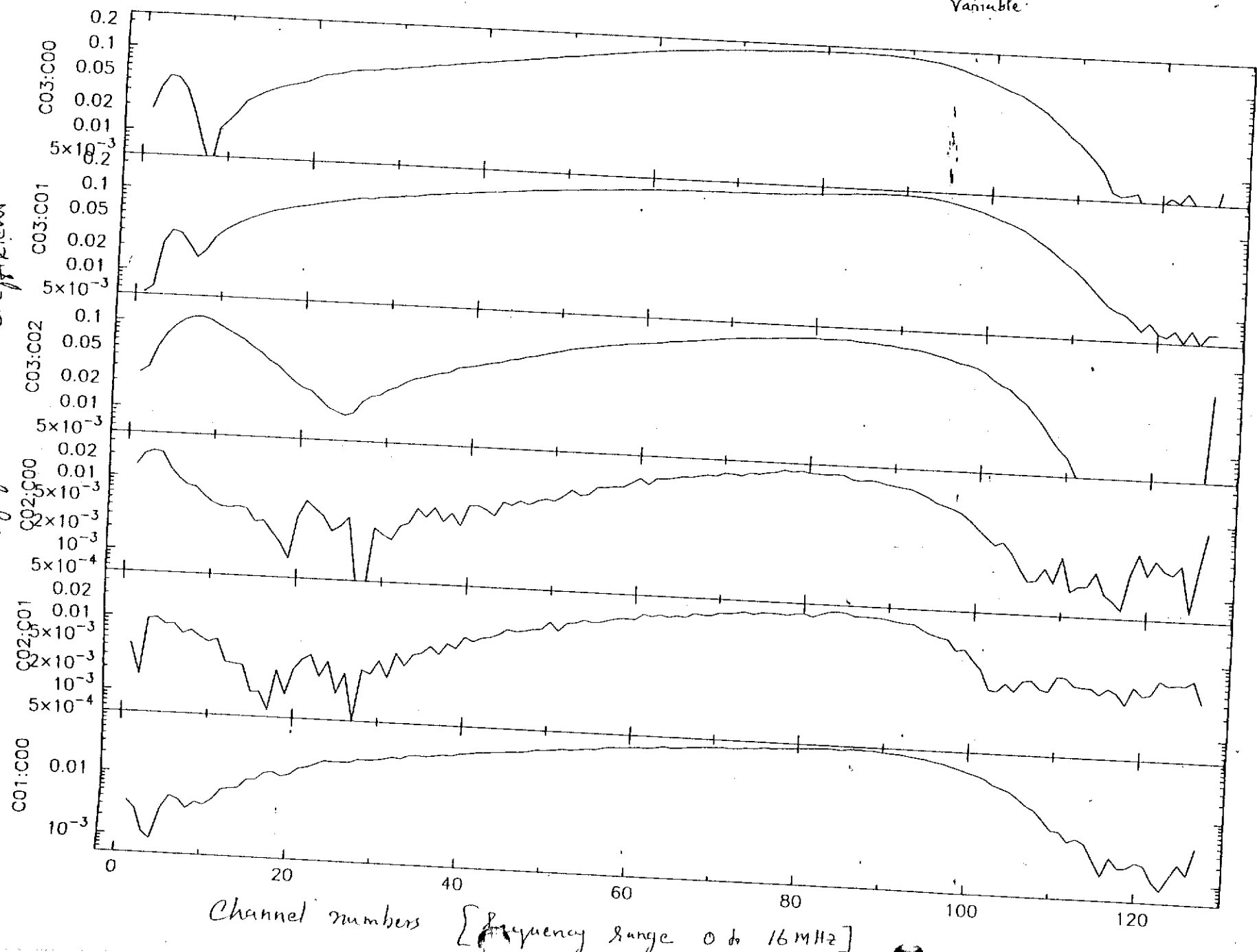

C00 - channel 1  
 C01 - channel 2  
 C02 - channel 3  
 C03 - channel 4

Fig. 8

Cross power spectrum when the common noise source is off.

Correlation Coefficient

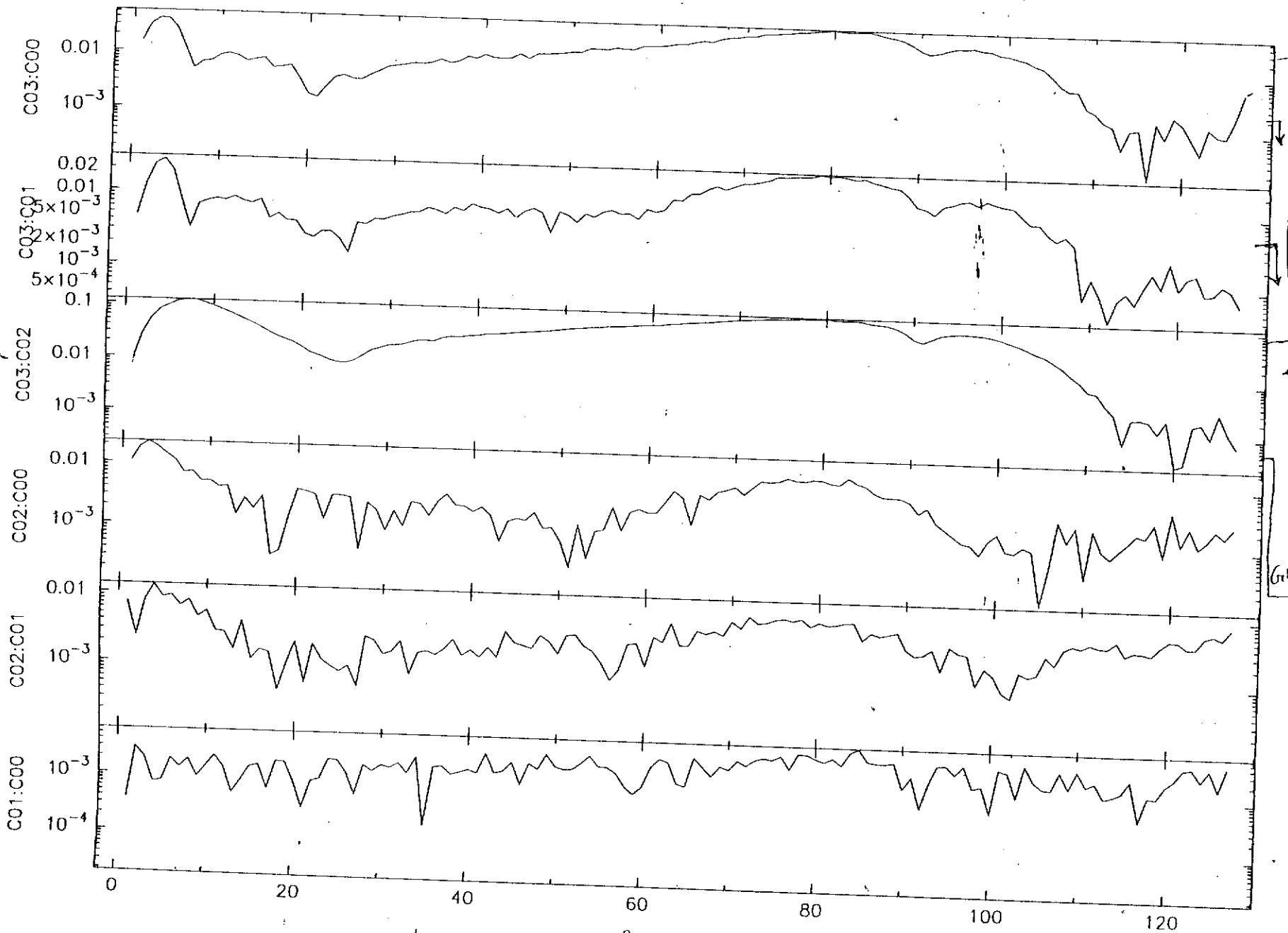

C00 - Channel 1  
 C01 - Channel 2  
 C02 - Channel 3  
 C03 - Channel 4

← Channel 4  
~~noise~~  
~~has more~~  
 has more coupling  
 the measurement  
 than ~~the~~ ~~limitation~~  
 limitation due to  
 the coupling in the  
 GMRT Correlator.

Fig 9

channel number [frequency range 0 to 16 MHz]