



National Centre for Radio Astrophysics

Tata Institute of Fundamental Research

Pune University Campus, Pune INDIA

GMRT 250–500 MHz FRONT END RECEIVER V-2

Bhalerao Vilas, S Suresh Kumar.

Front End Group.

Giant Metrewave Radio Telescope , Narayangaon, Khodad. 410504.

vilas@gmrt.ncra.tifr.res.in

Author : Bhalerao Vilas Verified by : <i>S Suresh Kumar</i>	Date of issue: 24/02/2015	Scope: Miniature size and weight of 250-500 MHz FE receiver version-02
Approved by : <i>S Suresh Kumar</i>	Status / Version :	Internal Technical Report No. : R-255

Abstract

The final frontend box design for the upgraded 250-500 MHz band with all RF modules and added monitoring features is explained in detail. This is the second version of this design which has optimized RF cable routing, DC cable routing, re-arranged units to accommodate all in the standard frontend box size uniform to the existing frontend boxes and thereby reducing the overall weight of the upgraded box by 9 kg so that the installation at antenna prime focus is possible without any modification to the antenna structure.

The document gives the details of all sub-units with their test report and bill of material of the frontend box for easy mass production for the remaining antenna upgrade.

The modified system was installed on C-11 Antenna on July 17, 2014 and the antenna test results are included for reference.

Acknowledgements

I am thankful to our Senior Engineer and Group Coordinator Mr. S. Sureshkumar , who has assigned me the job to design the integration , testing and installation all the electronics and chassis fixed in Ver.1 of 250-500 MHz Front End Box in Ver. 2 with existing small size FE box as per specified block diagram.

I am very much thankful for his guidance, constant encouragement, supervision, motivation and his support and help in preparing this report.

I am thankful to Prof. Yashwant Gupta (Dean-GMRT) and Prof. S K Ghosh (Center Director of NCRA-TIFR) for giving constant support during this work.

I am very much thankful to Mr. Santosh Bhor who helped in completing the assignment successfully.

I wish to express my sincere gratitude to all our front-end colleagues.

Index

Sr. No. CONTENTS	Page No.
1. Overview of GMRT Receiver System.	5
2. 250-500 MHz FRONT END V.2	6
3. Block diagram of 250-500 MHz FRONT END V.2	8
4. QUADRATURE HYBRID 250-500 MHz.	9
5. LOW NOISE AMPLIFIER.	12
6. DIRECTIONAL COUPLER.	14
7. BANDPASS AND NOTCH FILTER.	15
8. SUB BAND FILTER BANK.	17
9. PHASE SWITCH AND POST AMPLIFIER.	23
10. RF SWITCH.	24
11. DEFLECTION MEASURED	30
12. NOISE DEFLECTION MEASURED AT ANTENNA BASE	33
13. FRINGE STATUS	40
14. PHOTOGRAPH OF FE BOX 250-500 MHz V-2	41
15. WIRING DIAGRAM FOR RF SW6T SWITCH	45
16. BILL OF MATERIAL FOR 250-500 MHz FRONT END BOX V-2	46
17. MECHANICAL DRAWINGS OF VARIOUS CHASSIA AND FE BOX	48
18. DATASHEET OF HMC252QS24E GaAs MMIC SP6T Switch	52
19. CONCLUSION.	53
20. REFERENCES	54

1. Overview of GMRT Receiver System

Giant Meter-wave Radio Telescope (GMRT) currently operates at five observing bands centered at 150 MHz, 235 MHz, 327 MHz, 610 MHz and an L-band extending from 1000 to 1450 MHz. The L-band is split into four sub bands centered at 1060 MHz, 1170 MHz, 1280 MHz and 1390 MHz, each with a bandwidth of 120 MHz. The L-band receiver also has a bypass mode in which the entire RF band can be brought down to the Antenna Base Receiver (ABR).

The 150 MHz, 235 MHz, 327 MHz bands of GMRT have 40 MHz bandwidth and 610 MHz band has about 60 MHz of bandwidth. Lower frequency bands from 150 to 610 MHz have dual circular polarization which is named as CH1 and CH2 for right hand circular polarization and left hand circular polarization respectively. The higher frequency L-band has dual linear polarization (Vertical and Horizontal polarization) named CH1 and CH2 respectively. At the lower frequencies the polarizer placed before the Low Noise Amplifier (LNA) converts the received linear polarization to circular. At L-band, in order to keep the system temperature low, this element is not inserted into the signal path, and the linear polarized signals are fed directly to the LNA. To calibrate the gain of the receiver chain, it is possible to inject an additional noise signal (of known strength) into the input of the LNA. It is possible to inject noise at any one of four levels. These are called Low cal, Medium cal, High cal and Extra high cal and are of monotonically increasing strength.

To minimize crosstalk between different signals a phase switching facility using separate Walsh functions for each signal path is available at the RF section of the receiver.

At the Common Box the signals go through one additional stage of amplification. The common box has a broad band amplifier which covers the entire frequency range of the GMRT (10 – 1800 MHz). The band selector in the common box can be configured to take signals from any one of the six RF Front Ends. The common box (and the entire receiver system) has the flexibility to be configured for receiving either both polarizations at a single frequency band or a single polarization at each of two different frequency bands. It is also possible to swap the polarization channels whenever required. For observing strong radio sources like Sun, solar attenuators of 14 dB, 30 dB or 44 dB are available in the common box. In addition there is a power monitor whose output can be continuously monitored to verify the health of the subsystems upstream of the common box.

The first synthesized local oscillator converts the RF band to an IF band centered at 70 MHz. The synthesized local oscillator has a frequency range of 100 MHz to 1795 MHz. The frequency range 100 MHz to 600 MHz is covered by synthesizer-1 and 605 MHz to 1795 MHz is covered by synthesizer-2. The local oscillator frequency from 100 MHz to 354 MHz can be set with a step size of 1 MHz and the frequency range from 355 MHz to 1795 MHz can be set with a step size of 5 MHz. At the IF stage, bandwidth of 5.5 MHz, 16 MHz or a full available RF bandwidth can be selected. The IF at 70 MHz is then translated to a second IF at 130 MHz and 175 MHz for CH1 and CH2 respectively.

The maximum bandwidth available at this stage is 32 MHz for each polarization channel this frequency translation is done so that they can be transported to Central Electronics Building (CEB) over a single fiber optic cable. An Automatic Level Control (ALC) facility is provided at the output stage of IF which can be bypassed whenever required.

The IF signal at 130 MHz and 175 MHz along with telemetry and LO round trip phase carriers directly modulate a laser diode operating at 1300 nm wavelength which is coupled to a single mode fiber-optic link between the receiving antennas and the CEB.

2. 250-500 MHz FRONT END V.2

The existing system of front-end receiver gets its input from Kildal Feed with cone reflector located at the prime focus of the GMRT antenna.

It consists of orthogonal pairs of two crossed dipoles.

The present front-end system consists of the following sub-systems:

Polarizer

The polarizer present in the front-end box transforms linear vertical and horizontal polarized signals received from the orthogonal dipole feed into right and left circularly polarized signals. The two circularly polarized channels are known as CH1 and CH2.

The polarizer is of TEMLINE Octave Band from Sage Laboratories with low loss since the polarizers are placed before the LNA. The insertion loss of the existing polarizer is 0.1 dB.

Low Noise Amplifier (LNA)

The low noise amplifiers are placed immediately after the low loss polarizers. Usually LNA is placed in the front-end portion of the system and its noise temperature determines the system noise properties. This is because by Friis' formula, if the gain of the first device is very high and noise temperature is very less, then the noise temperature of the entire receiver system is governed by its noise temperature.

The present 250-500 MHz LNA design is based on Agilent Technologies's ATF-54143 is a high dynamic range, low noise, E-PHEMT housed in a 4-lead SC-70 (SOT-343) surface mount plastic package. It has a gain of 30 dB, a bandwidth of 250 MHz, a noise figure of 0.41 dB and a noise temperature of 30 °K.

To calibrate the gain of the receiver chain, it is possible to inject an additional noise signal (of known strength) into the input of LNA. It is possible to inject noise at any one of four levels:

(1. Low cal - 10 %, 2. Medium cal - 40 %, 3. High cal - 100 %, 4. Extra high cal - 400 %)

This is done using the microstrip Directional Coupler .

Band Pass Filter

The band pass filter after the low noise amplifier is used to select a wide band of frequencies from 250-500 MHz. It is also useful for rejecting unwanted interference signal and for image rejection. The present band pass filter has a bandwidth of only 250 MHz around central frequency.

Band Stop(Notch) Filter

The band stop filters of 177 MHz and 540 MHz is used in series to reject unwanted TV signals for both the channels.

Switch Filter Bank

The switch filter bank consists of four sub bands, 240-340 MHz, 300-400 MHz, 360-460 MHz, and 420-520 MHz along with 250-500 MHz main band pass filter. Each sub band is 100 MHz bandwidth (6 dB points). For selecting any sub band ,we have used Hittite make GaAs MMIC SP6T non reflective switch (HMC252QS24E).

The HMC252QS24E is low cost SP6T switch in 24 lead QSOP package featuring wideband operation from DC to 3.0 GHz.

The switch offers a single positive bias and true TTL/CMOS compatibility. A 3:6 decoder is integrated on the switch requiring only 3 control lines and a positive bias to select each path. The switch has low Insertion loss of 1.0 dB , Isolation of 41 dB , 24 dBm Input Power of 1 dB Compression and 46 dBm Input Third order Intercept.

Post Amplifier and Phase Switch

The bandpass filter is followed by a post amplifier to have the required output power at the end of front end box. The amplifiers being used presently are the Mini-circuits MMIC amplifiers MAV-11 with a gain of 12.5 dB and noise figure of 3.6 dB. We have replaced this device with high dynamic range Hittite make HMC-740 with a gain of 14 dB and OIP3 of +40 dBm.

Thereafter the signal is modulated with Walsh function using phase switching to minimize the effect of crosstalk between different signals. Mini-circuits double balanced mixer SBL-1MH is used for phase-switching.

RF on/off facility is provided for connecting and disconnecting a channel by means of RF switch SW-239 having an insertion loss of about 0.50 dB.

Power and Temperature Monitoring

Two RF power monitoring units are used for monitoring CH-1 and CH-2 total power. Two temperature units are used to monitor temp. inside LNA and FE box,

Band Selector

All frequency bands converge at the band selector which then selects any one of the six bands and passes it on for further processing in the Common Box. The band selector design is based on GaAs FET MMIC RF switches. It can be configured either to receive both polarizations at a single frequency band or a single polarization at each of the two frequency bands, if any such need arises.

Solar Attenuator

This attenuator is used while observing Sun or any other strong radio sources. If the radiations are too high then they are attenuated to prevent the following circuitry from getting saturated. Solar attenuator has a set of two attenuators i.e. 14 dB and 30 dB. A maximum of 44 dB and a minimum of 0 dB can be attained using these two. Also this facilitates the band selector and the channel swap to terminate on 14 dB and 30 dB variable attenuators respectively.

Channel Swap Switch

The channel swap switch is designed using a set of GaAs FET MMIC RF switches. Using this facility, the polarization channels can be swapped whenever required. It also helps in fault detection.

Broadband Amplifier

It is design with two high dynamic range Hittite make HMC-740 devices in cascade.

It has a gain of approximately 30 dB.

After this follow a pair of low-loss foam cables which transport the signals from the front end box to the Antenna Base Receiver.

3. BLOCK DIAGRAM

BLOCK DAIGRAM OF GMRT 250-500 MHz FRONT END RECEIVER V-2

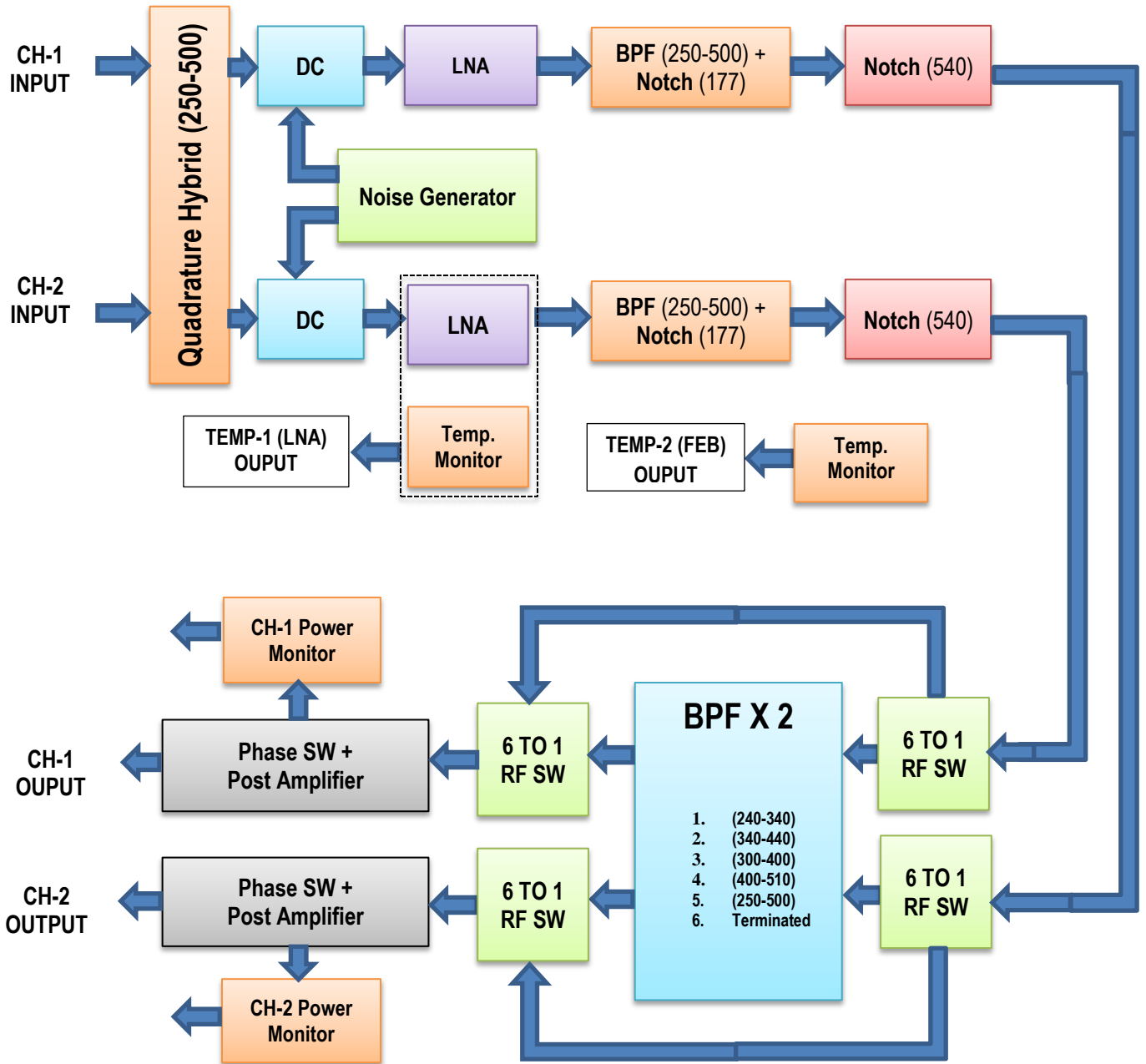

GMRT/FES/VBB/SSK/2014

A 3 dB, 90° hybrid coupler is a four-port device that is used either to equally split an input signal with a resultant 90° phase shift between output ports or to combine two signals while maintaining high isolation between the ports.

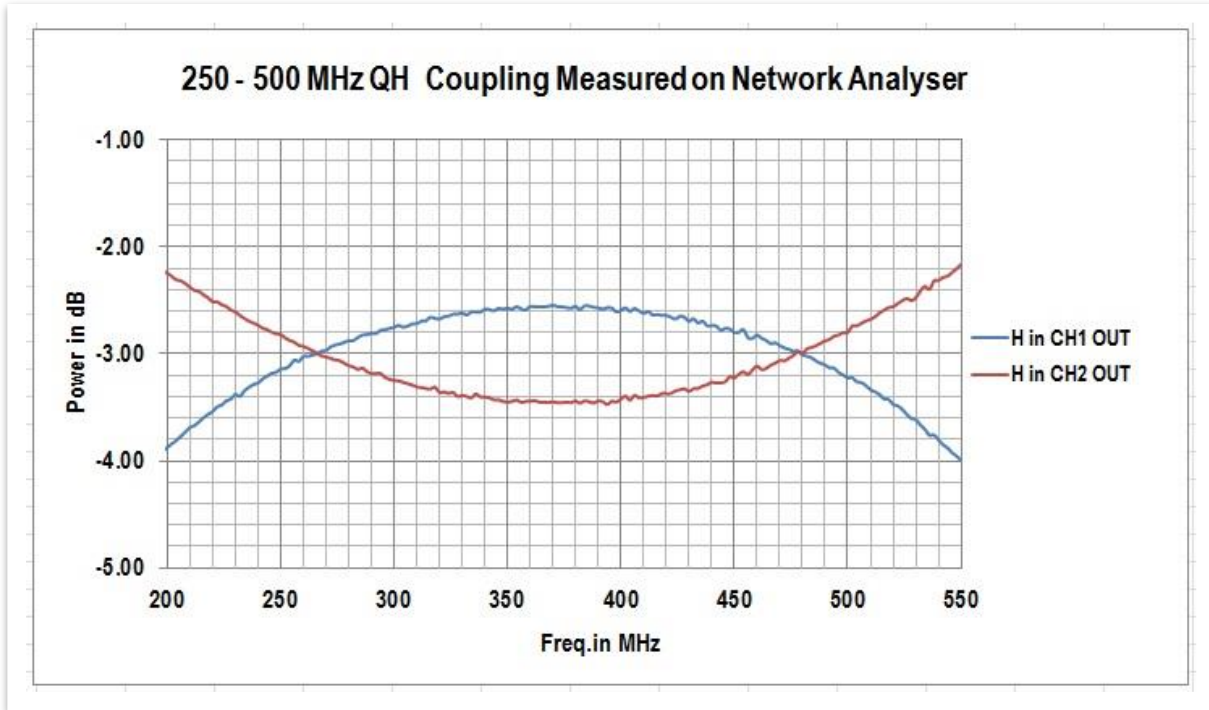

Figure 1 (H Input Port and CH-1 and CH-2 Coupling measured on Network)

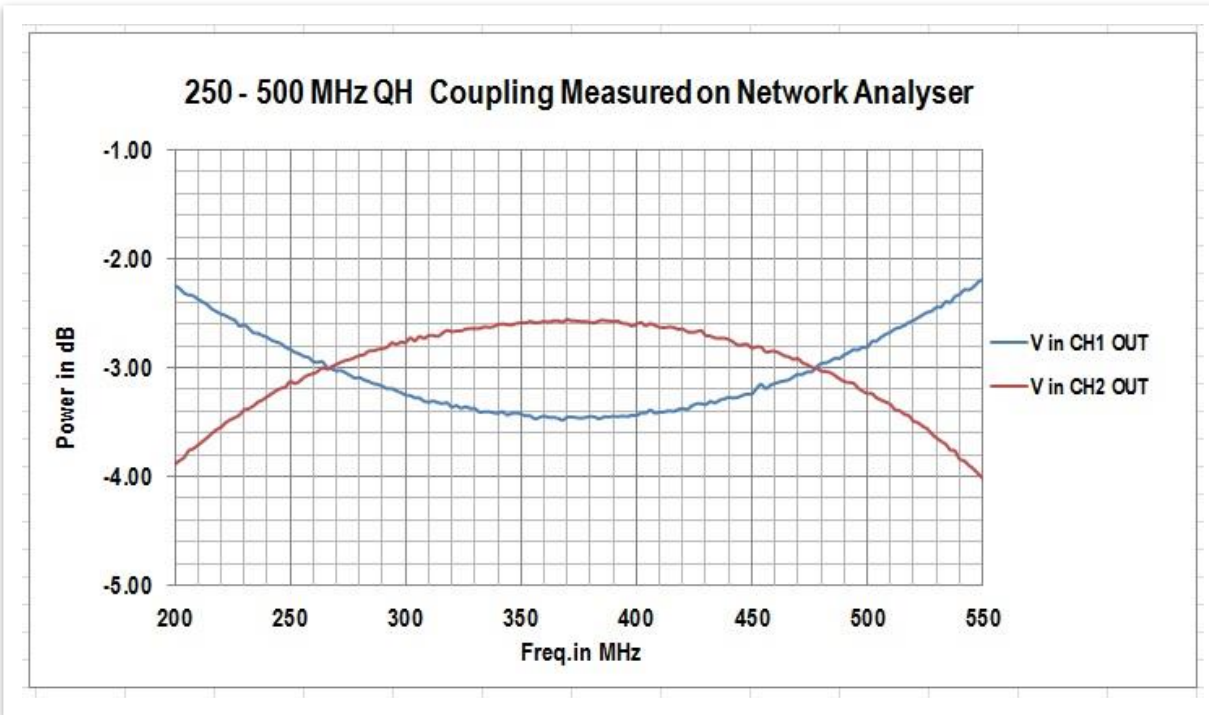

Figure 2 (V Input Port and CH-1 and CH-2 Coupling measured on Network)

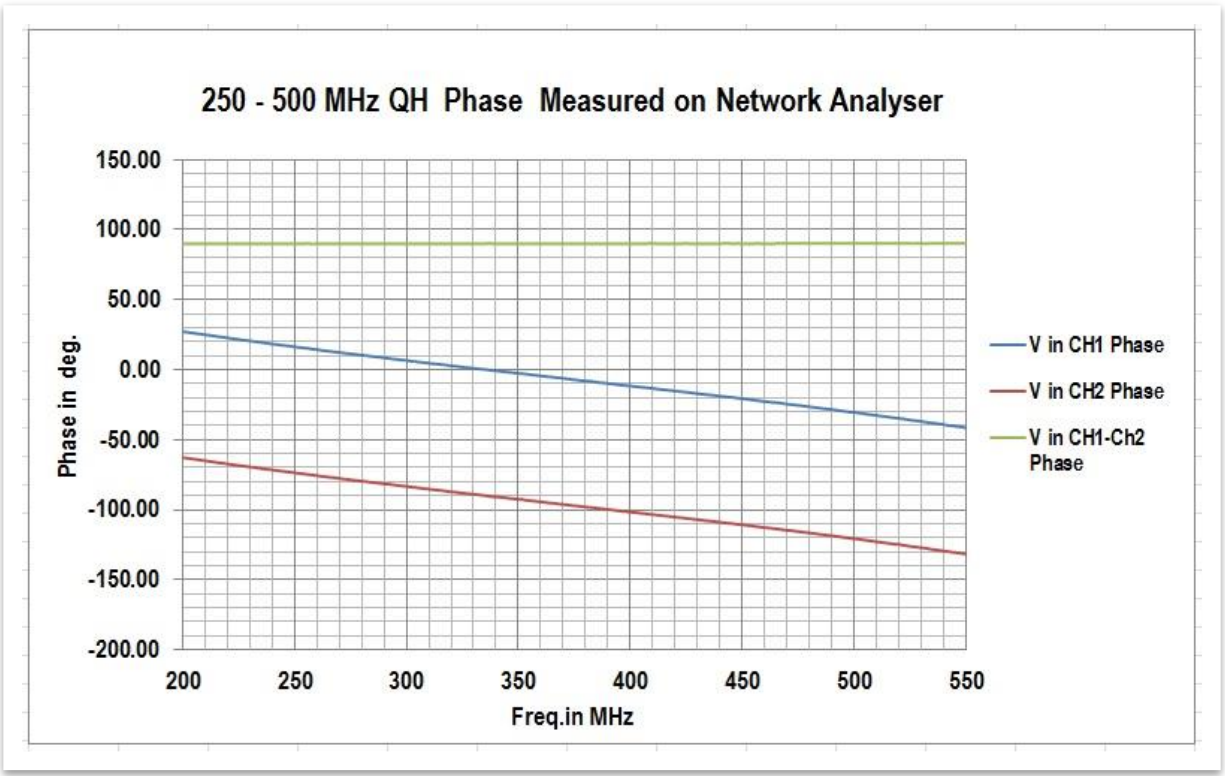

Figure 3 (V Input Port and CH-1 and CH-2 Phase measured on Network)

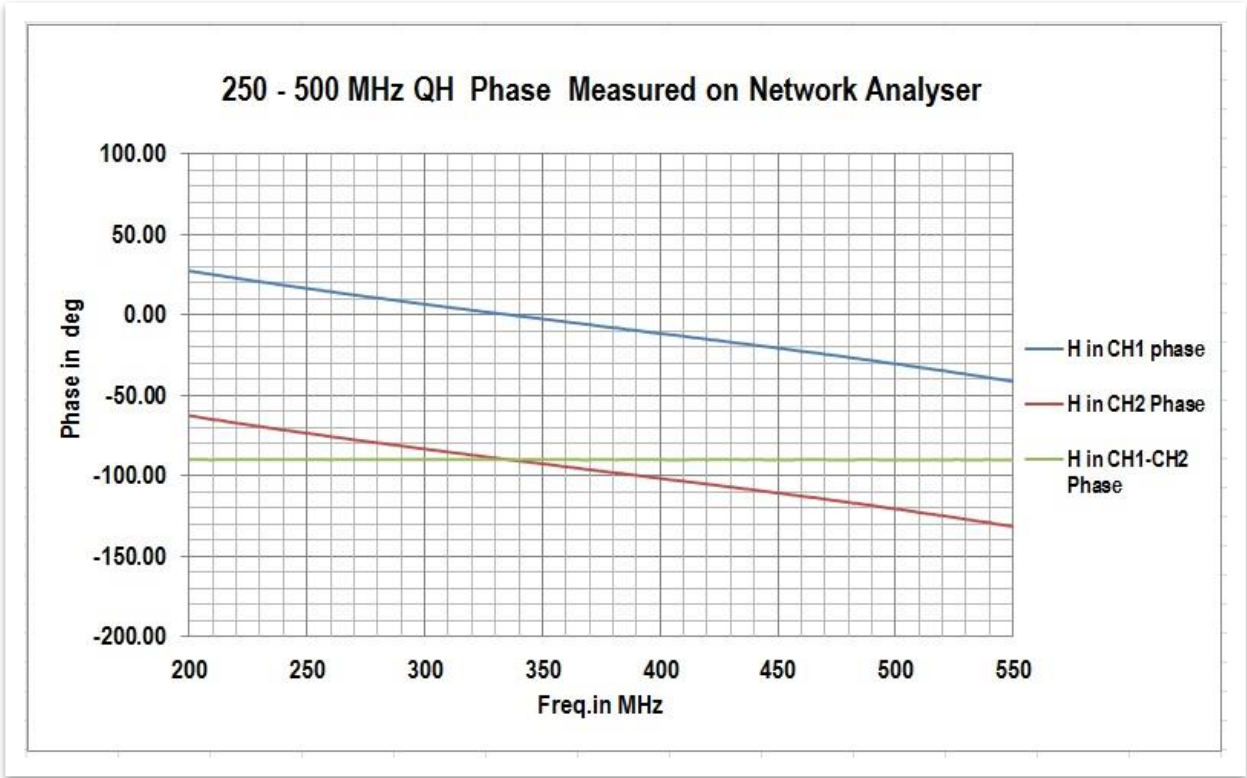
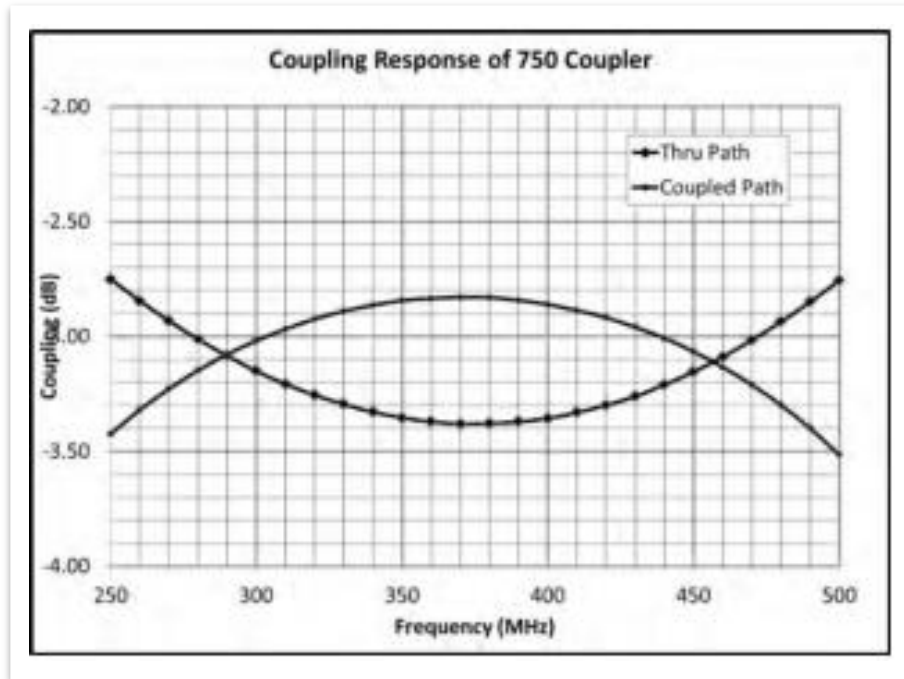

Figure 4 (H Input Port and CH-1 and CH-2 Phase measured on Network)

Figure 5 (Coupling Response given in datasheet)



SUMMARY REPORT OF QH

Sr.No.	Parameters	Expected	CH-1	CH-2
1	Frequency Range	250-500 MHz	250-500 MHz	250-500 MHz
2	Insertion Loss	0.1 dB	0.1 dB	0.1 dB
3	Phase	90±1 °	90±1 °	90±1 °

5. LOW NOISE AMPLIFIER¹

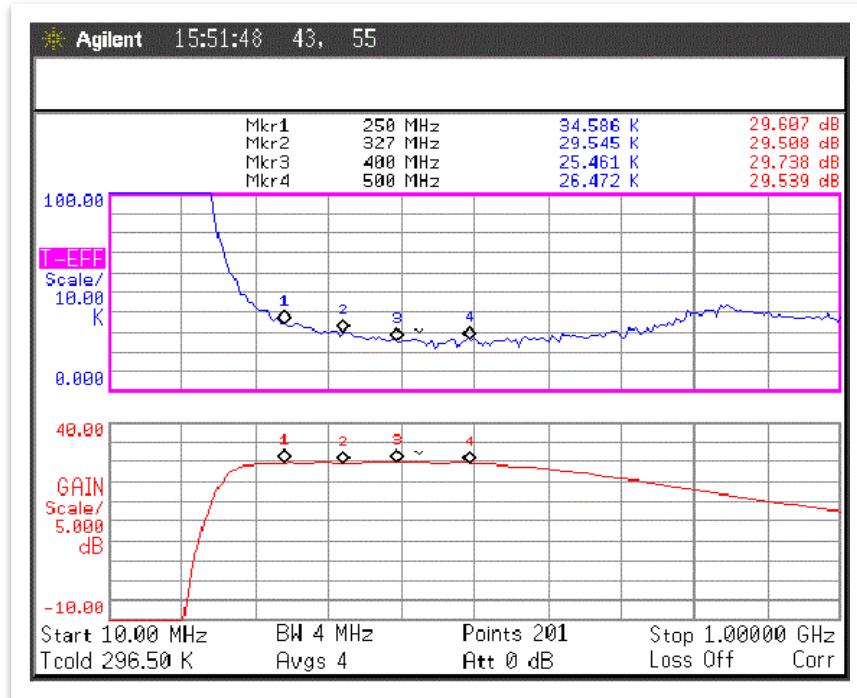

Figure 6 (CH-1 LNA Noise temp. and Gain measured on NFA)

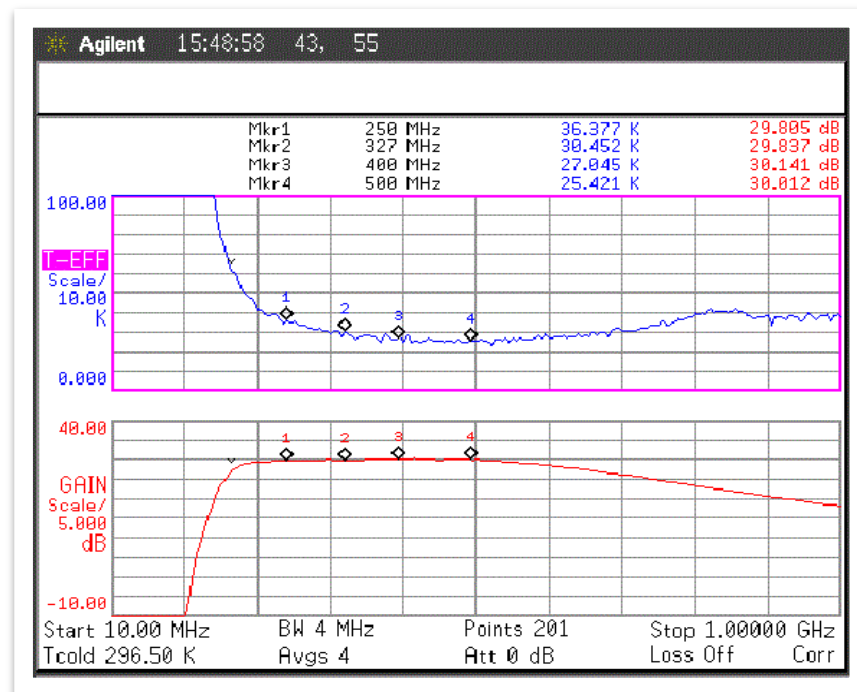

Figure 7 (CH-2 LNA Noise temp. and Gain measured on NFA)

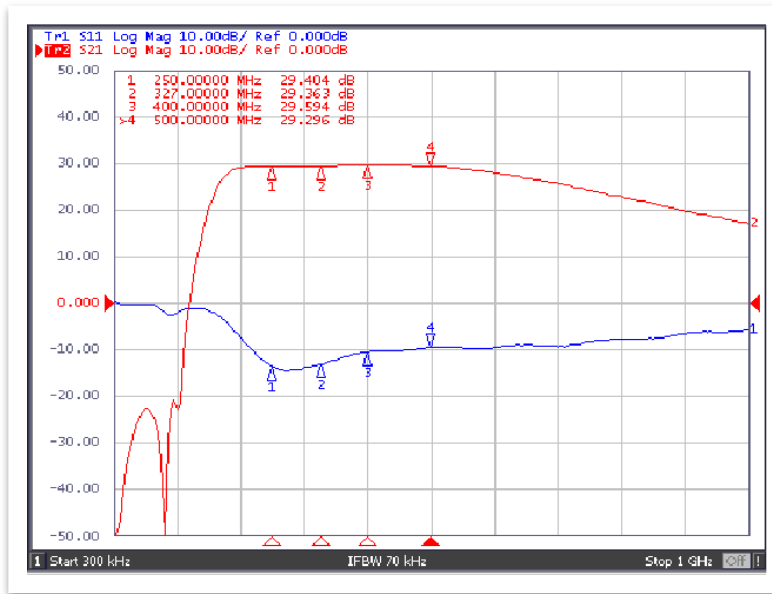

Figure 8 (CH-1 LNA Gain and Input Return Loss measured on Network)

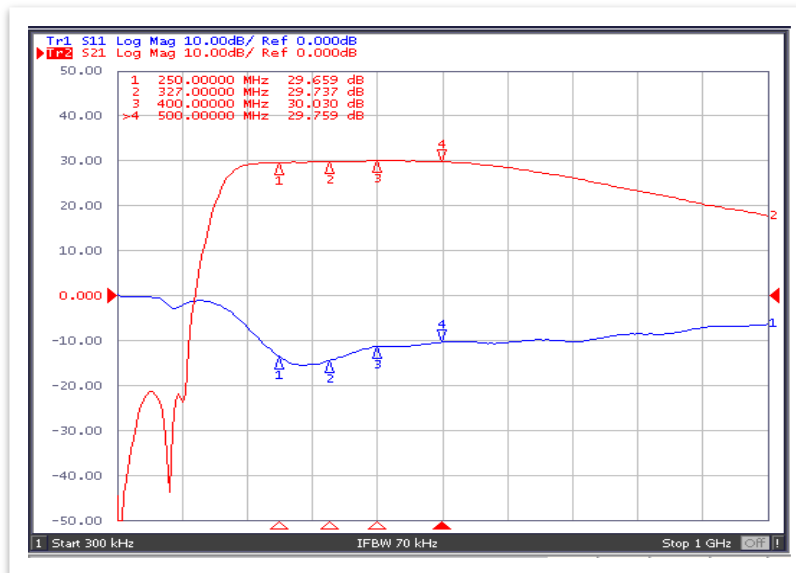

Figure 9 (CH-2 LNA Gain and Input Return Loss measured on Network)

SUMMARY REPORT OF LNA

Sr.No.	Parameters	Expected	CH-1	CH-2
1	Noise temperature	25 °K	26.5 to 34.5 °K	25.5 to 36.4 °K
2	Gain	30 dB	29.5 dB	30.0 dB
3	Input Return Loss	-10 dB	-10 to -14 dB	-10 to -14 dB
4	Output Return Loss	-10 dB	-15 to -18 dB	-15 to -18 dB

6. DIRECTIONAL COUPLER 250-500 MHz¹

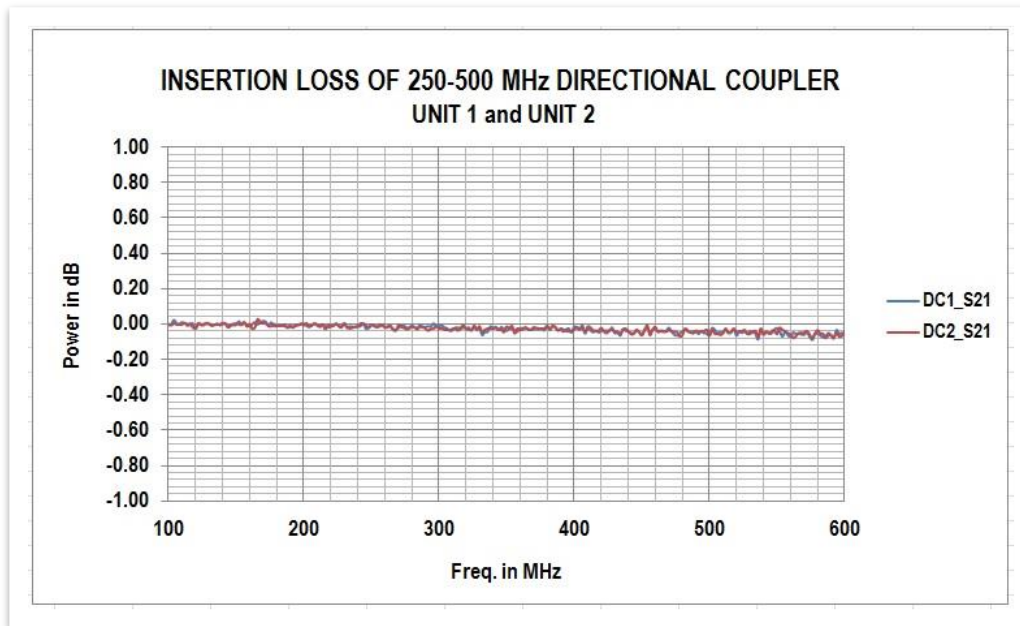

Figure 10 (CH1 and CH-2 Insertion Loss in dB measured on Network)

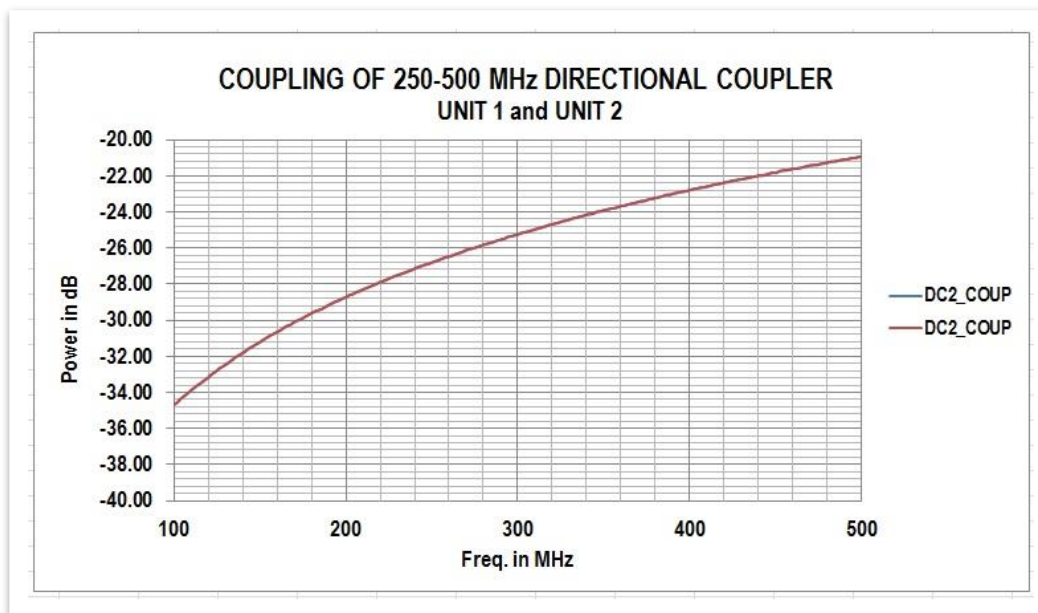

Figure 11 (CH-1 and CH-2 Coupling in dB measured on Network)

SUMMARY REPORT OF DIRECTIONAL COUPLER

Parameters	CH-1	CH-2	Parameters	CH-1	CH-2
Coupling at 250 MHz	26.8 dB	26.8 dB	Loss at 250 MHz	0.004 dB	0.005 dB
Coupling at 327 MHz	24.5 dB	24.5 dB	Loss at 327 MHz	0.025 dB	0.015 dB
Coupling at 500 MHz	21.0 dB	20.9 dB	Loss at 500 MHz	0.056 dB	0.057 dB

7. BAND PASS FILTER 250-500 MHz and BAND STOP FILTER 177 MHz , 540 MHz

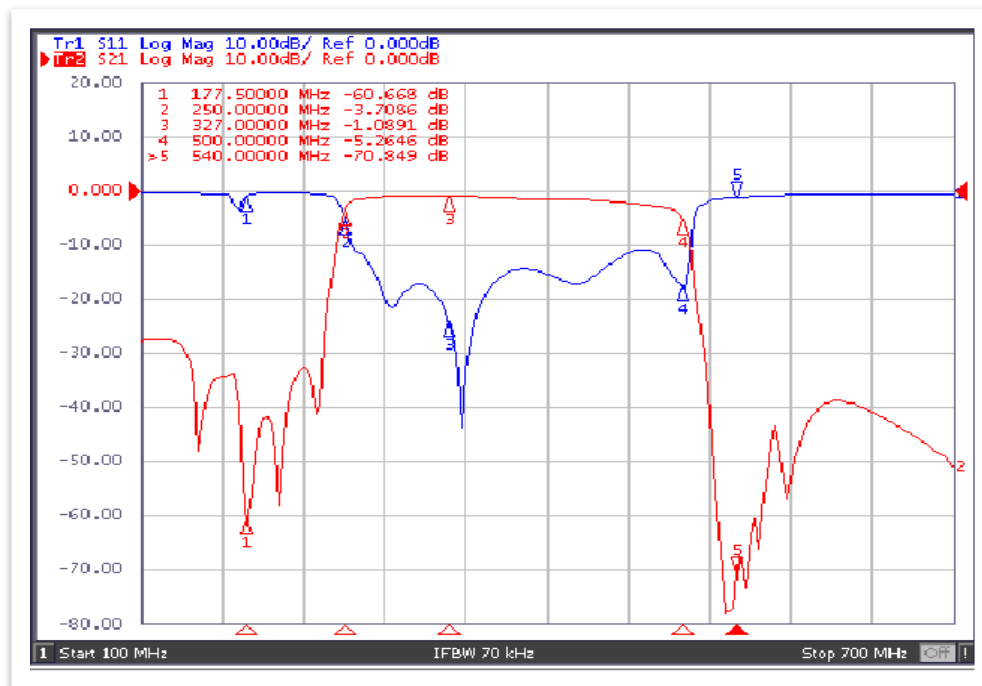

Figure 12 (CH-1 Frequency response of BPF and Notch filters)

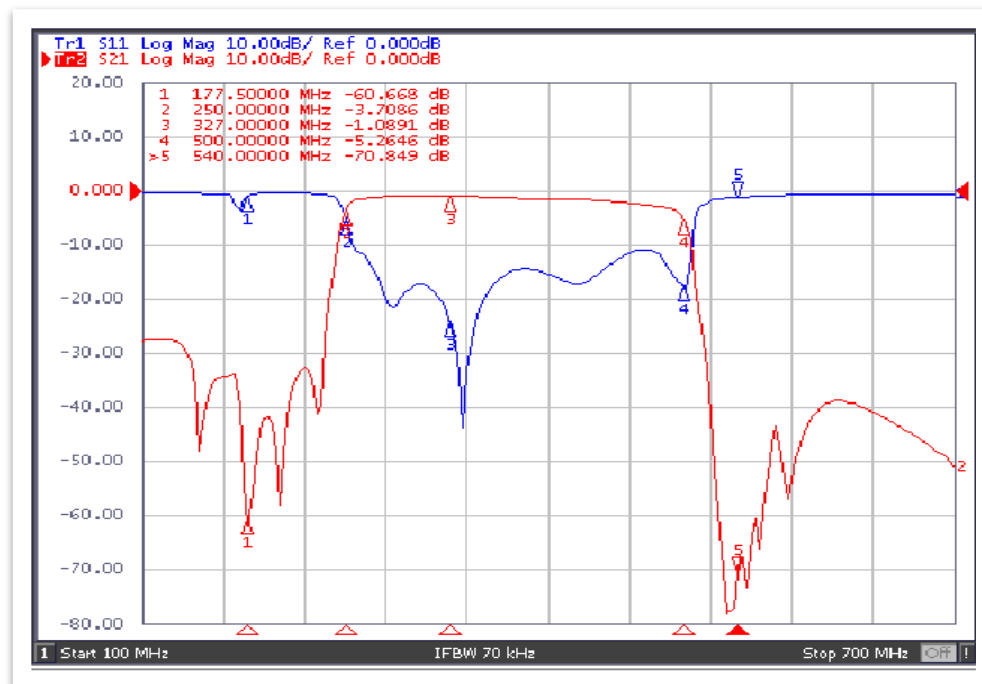

Figure 13 (CH-2 Frequency response of BPF and Notch filters)

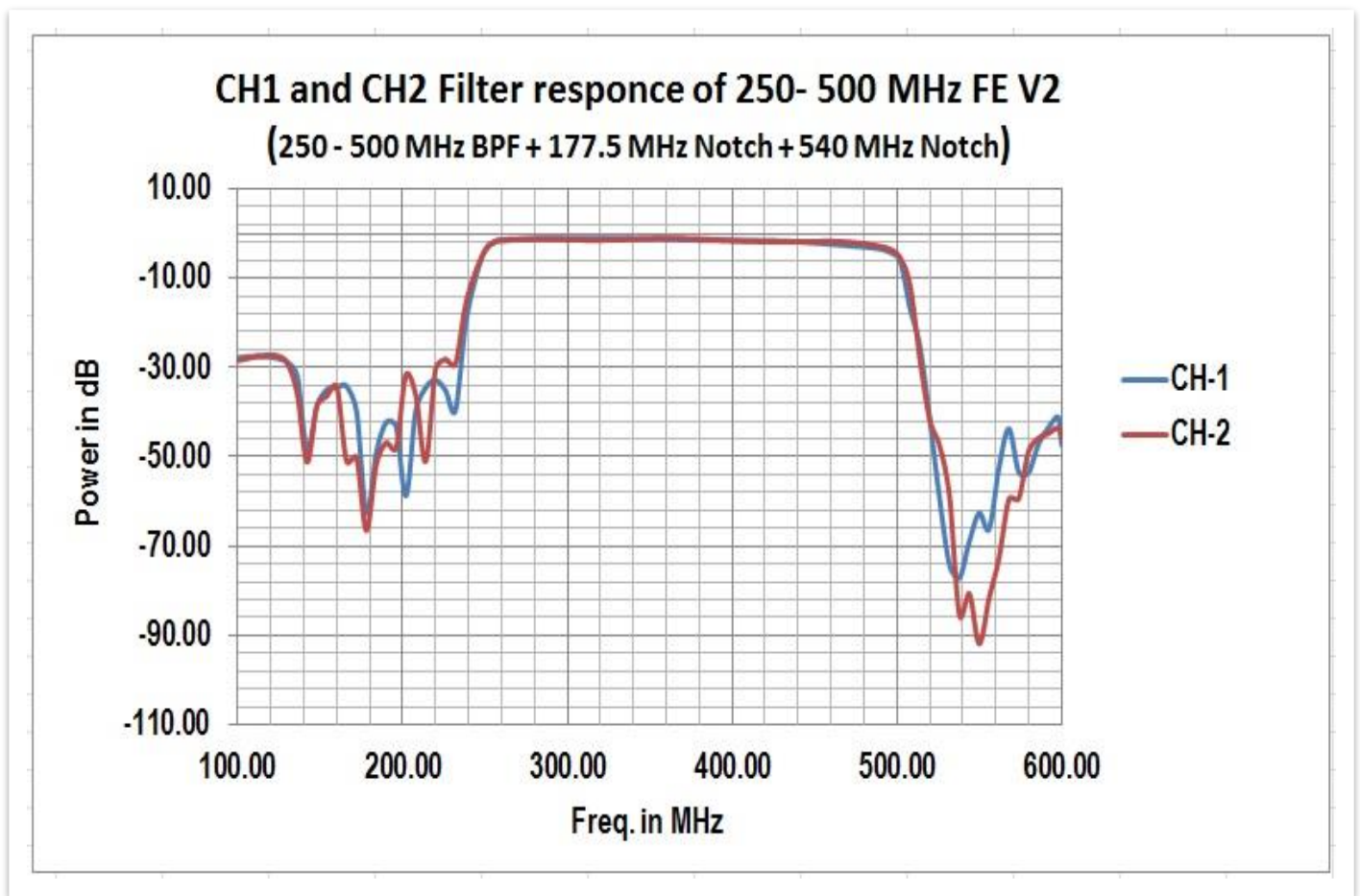

Figure 14 (CH-1 and CH-2 Frequency response of BPF and Notch filters)

SUMMARY BPF and NOTCH

Sr.No.	Parameters	Expected	CH-1	CH-2
1	Band pass filter BW	250- 500 MHz	250- 500 MHz	250- 500 MHz
2	Pass band Insertion Loss	1.0 dB	1.0 dB	1.0 dB
3	Pass band Return Loss	-10 dB	-10 dB to -18 dB	-10 dB to -18 dB
4	Notch rejection at 177 MHz	-40 dB	-60 dB	-60 dB
5	Notch rejection at 540 MHz	-40 dB	-70 dB	-70 dB

8. SUB-BAND FILTER³

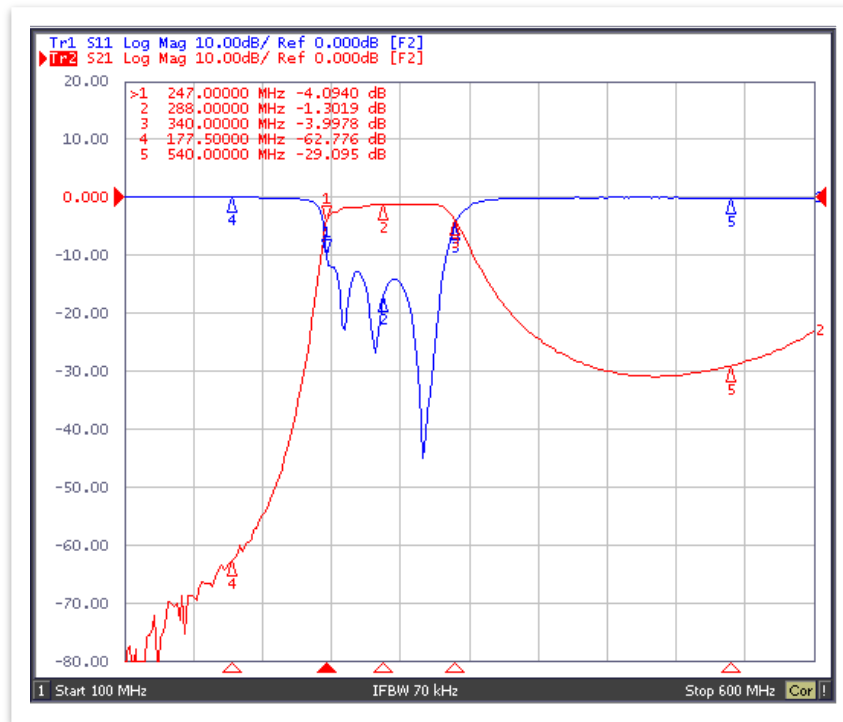

Figure 15 (CH-1 Frequency response of 240-340 MHz BPF)

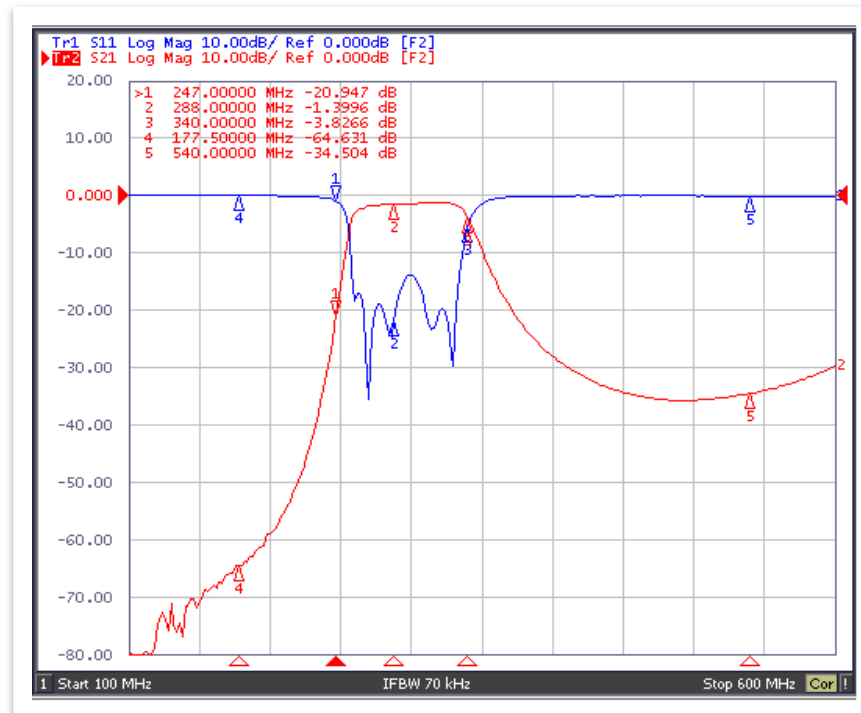

Figure 16 (CH-2 Frequency response of 240-340 MHz BPF)

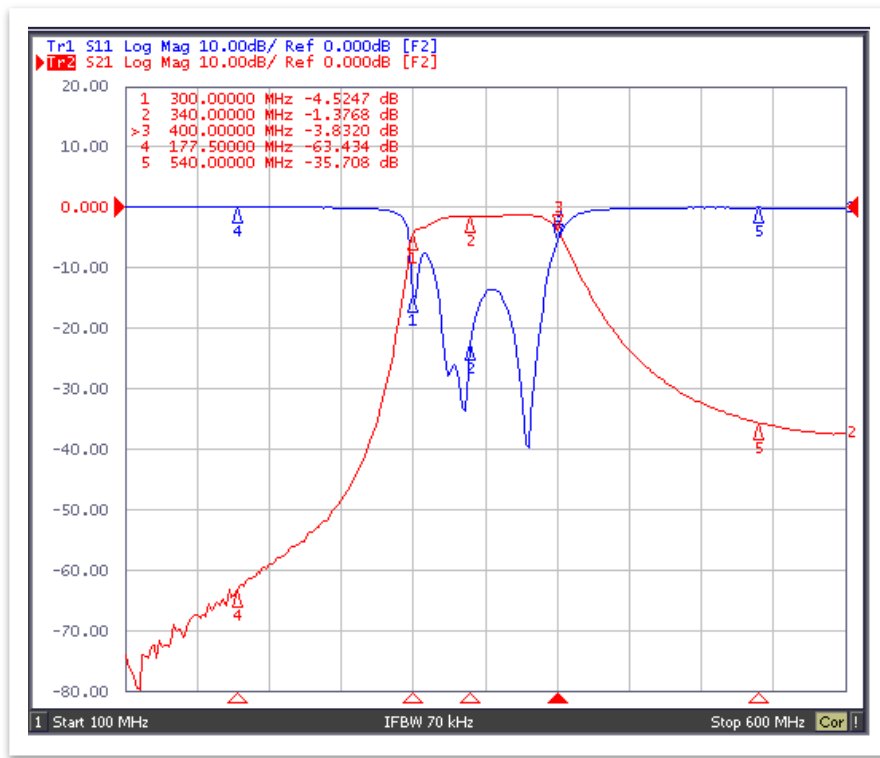

Figure 17 (CH-1 Frequency response of 300-400 MHz BPF)

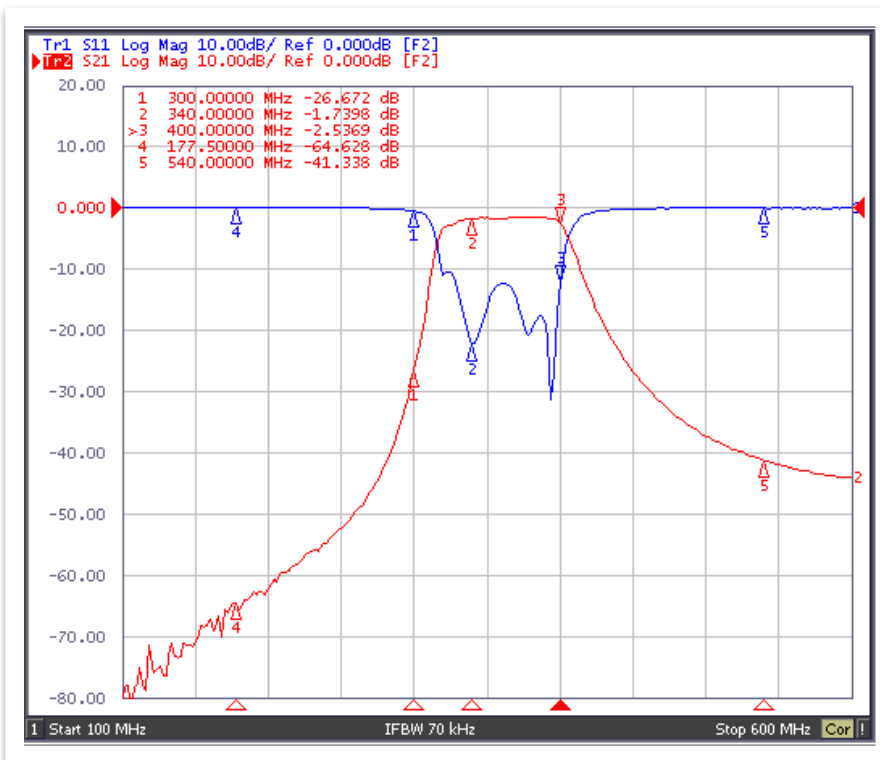

Figure 18 (CH-2 Frequency response of 300-400 MHz BPF)

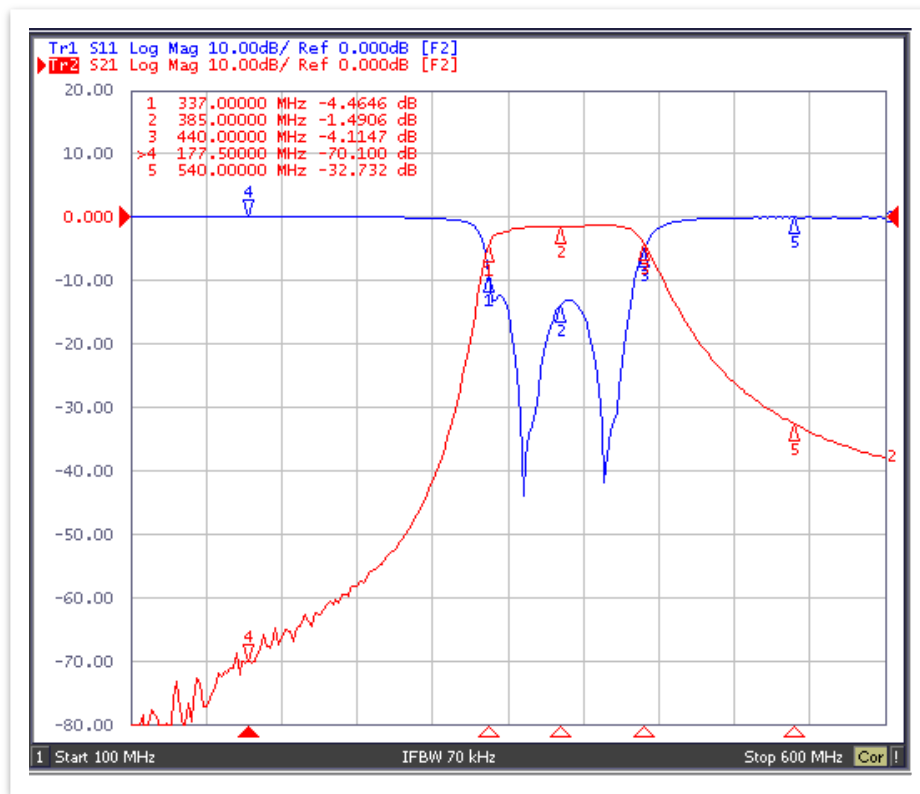

Figure 19 (CH-1 Frequency response of 340-440 MHz BPF)

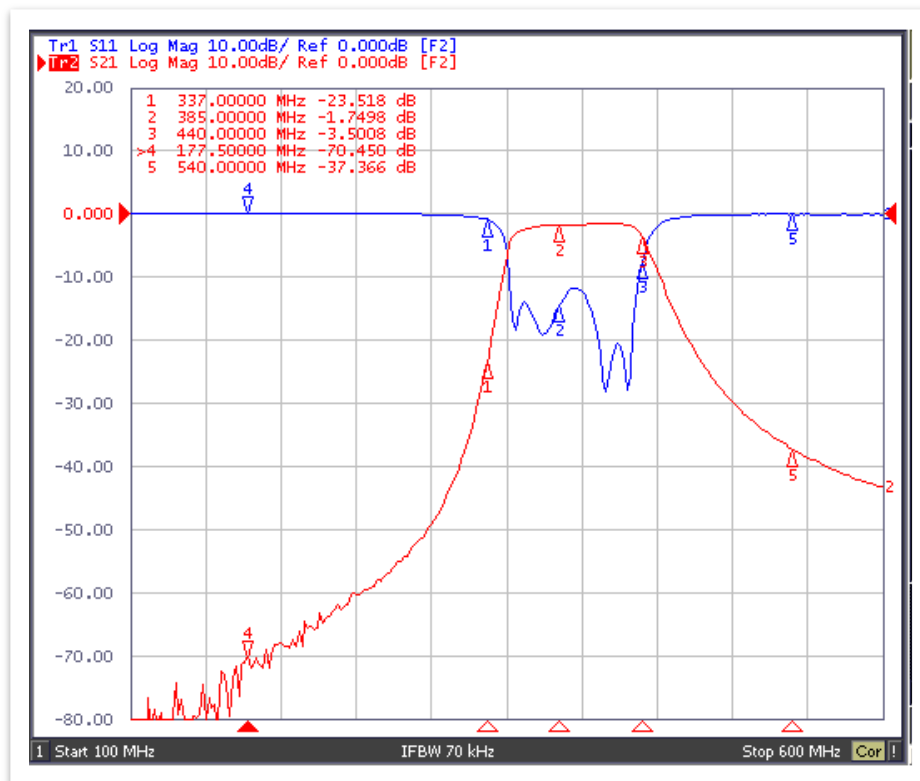

Figure 20 (CH-2 Frequency response of 340-440 MHz BPF)

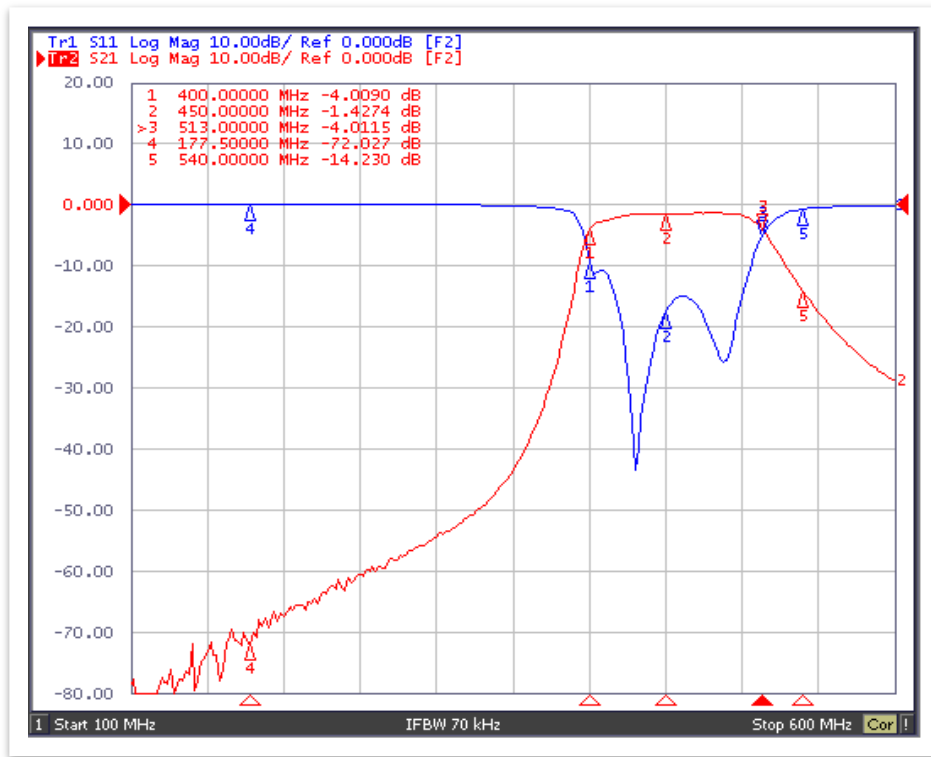

Figure 21 (CH-1 Frequency response of 400-500 MHz BPF)

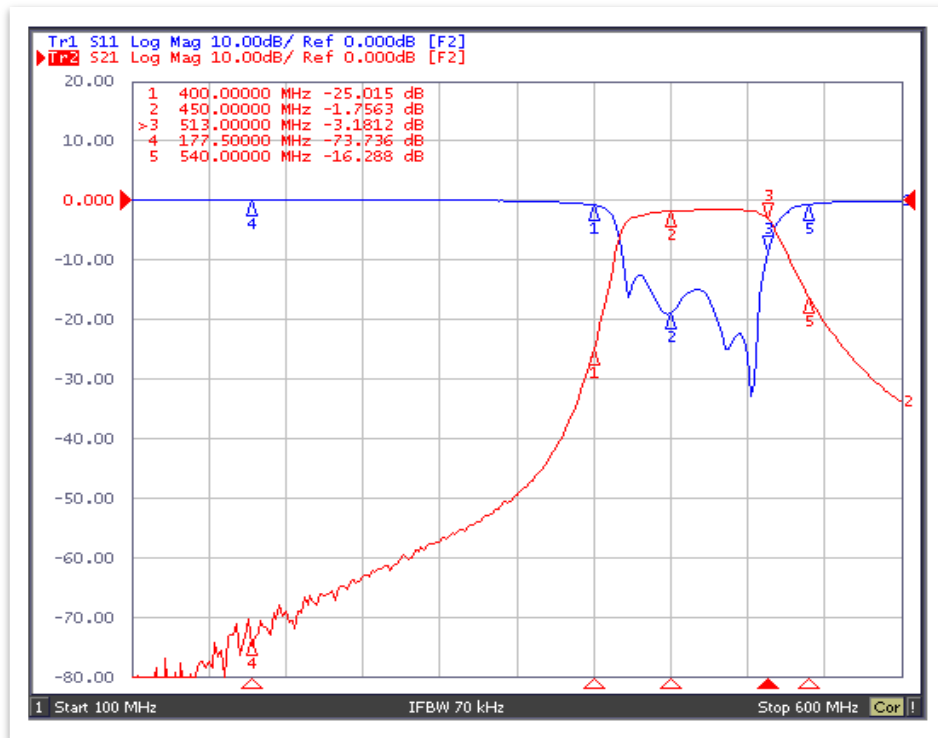

Figure 22(CH-2 Frequency response of 400-500 MHz BPF)

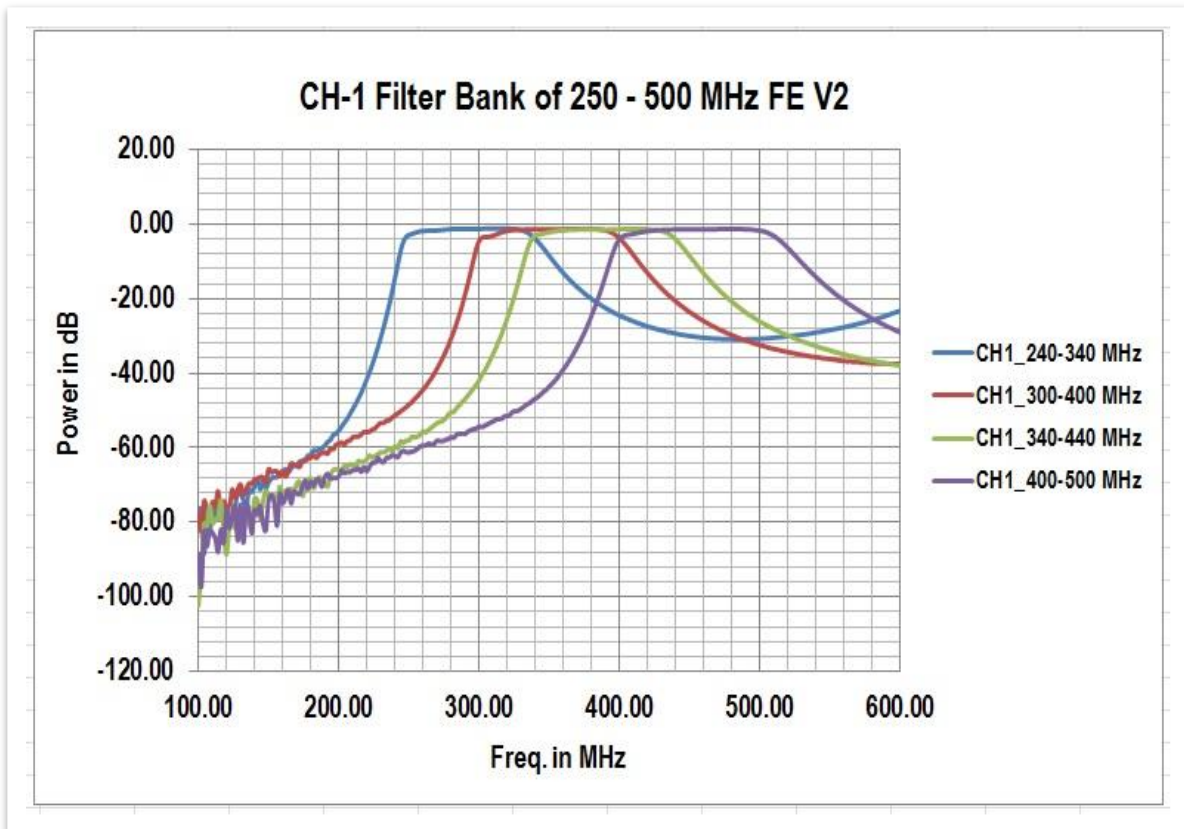

Figure 23(CH-1 Frequency response of Filter Bank)

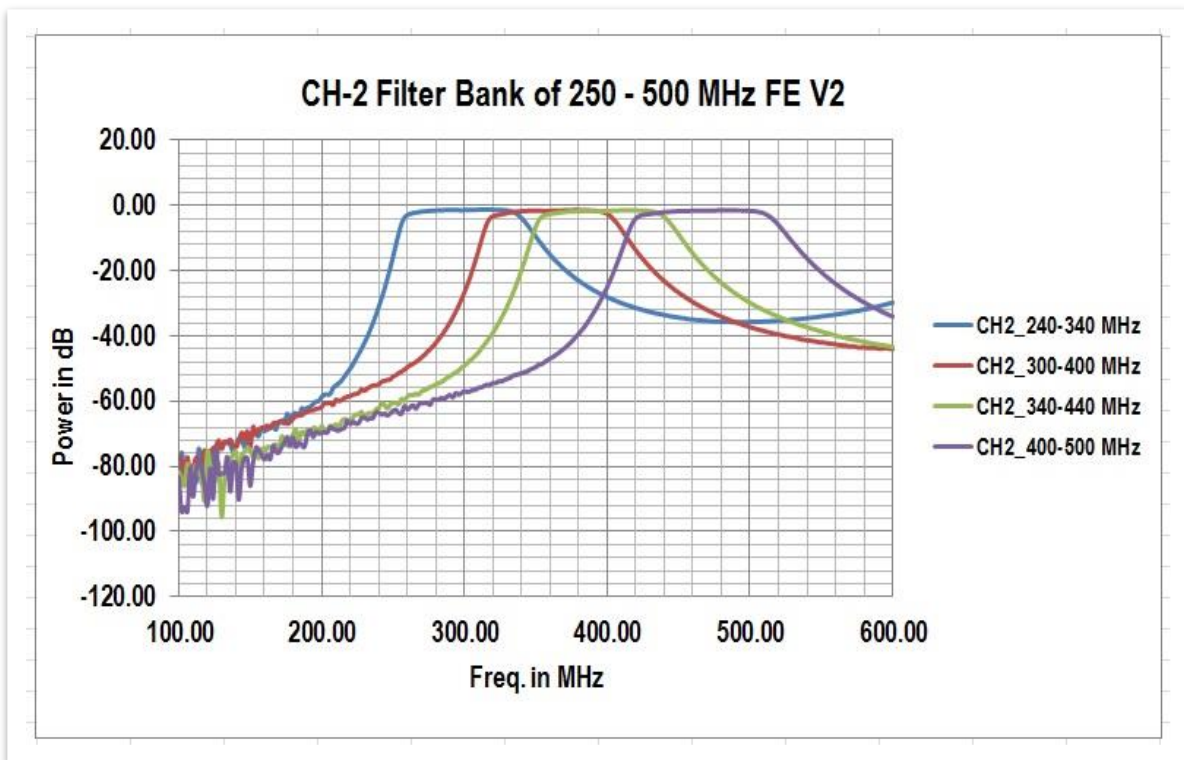

Figure 24(CH-2 Frequency response of Filter Bank)

SUMMARY OF SUB-BAND FILTER

S.No.	Parameters	Expected	CH-1	CH-2
1	240-340 MHz Insertion Loss	1.0 dB	1.3 dB	1.4 dB
2	300-400 MHz Insertion Loss	1.0 dB	1.4 dB	1.7 dB
3	340-440 MHz Insertion Loss	1.0 dB	1.5 dB	1.7 dB
4	400-500 MHz Insertion Loss	1.0 dB	1.4 dB	1.7 dB
5	240-340 MHz Return Loss	-10 dB	-13 dB	-14 dB
6	300-400 MHz Return Loss	-10 dB	-15 dB	-13 dB
7	340-440 MHz Return Loss	-10 dB	-12 dB	-13 dB
8	340-440 MHz Return Loss	-10 dB	-15 dB	-15 dB

Note:

There is some offset (~ 10 to 15 MHz) due to critical spacing (4 mil) between PCB tracks of sub-band filter .

9. PHASE SWITCH and POST AMPLIFIER

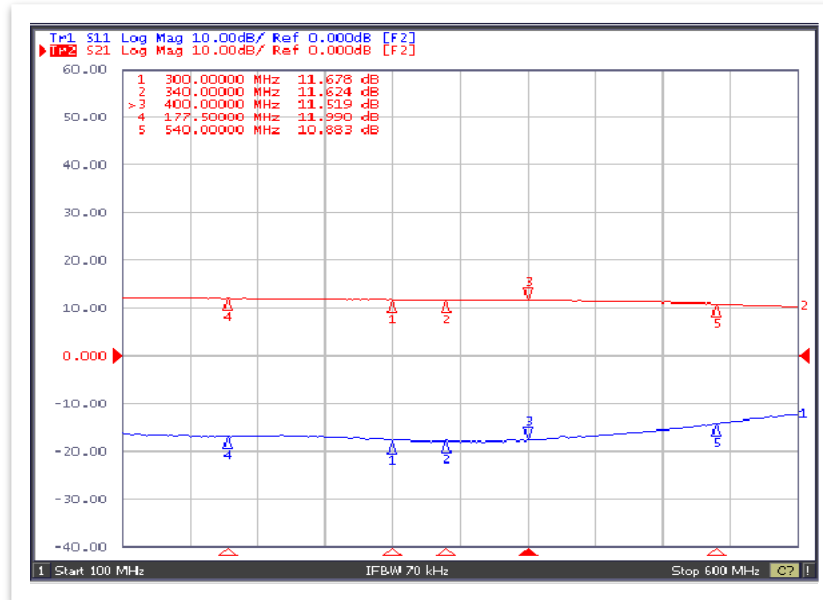

Figure 25(CH-1 S21 and S11 of Phase SW Amplifier)

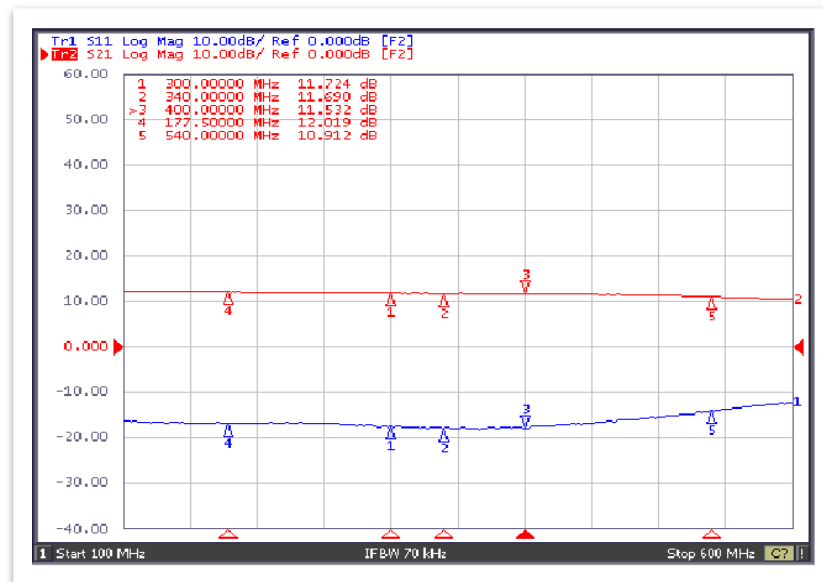

Figure 26 (CH-2 S21 and S11 of Phase SW Amplifier)

SUMMARY REPORT OF PHASE SW AMPLIFIER

Parameters	Expected	CH-1	CH-2
250-500 MHz Gain	11.0 dB	11.6 dB	11.6 dB
250-500 MHz Return Loss	-10 dB	-18 dB	-18 dB

10. SW6T RF SWITCH INSERTION LOSS

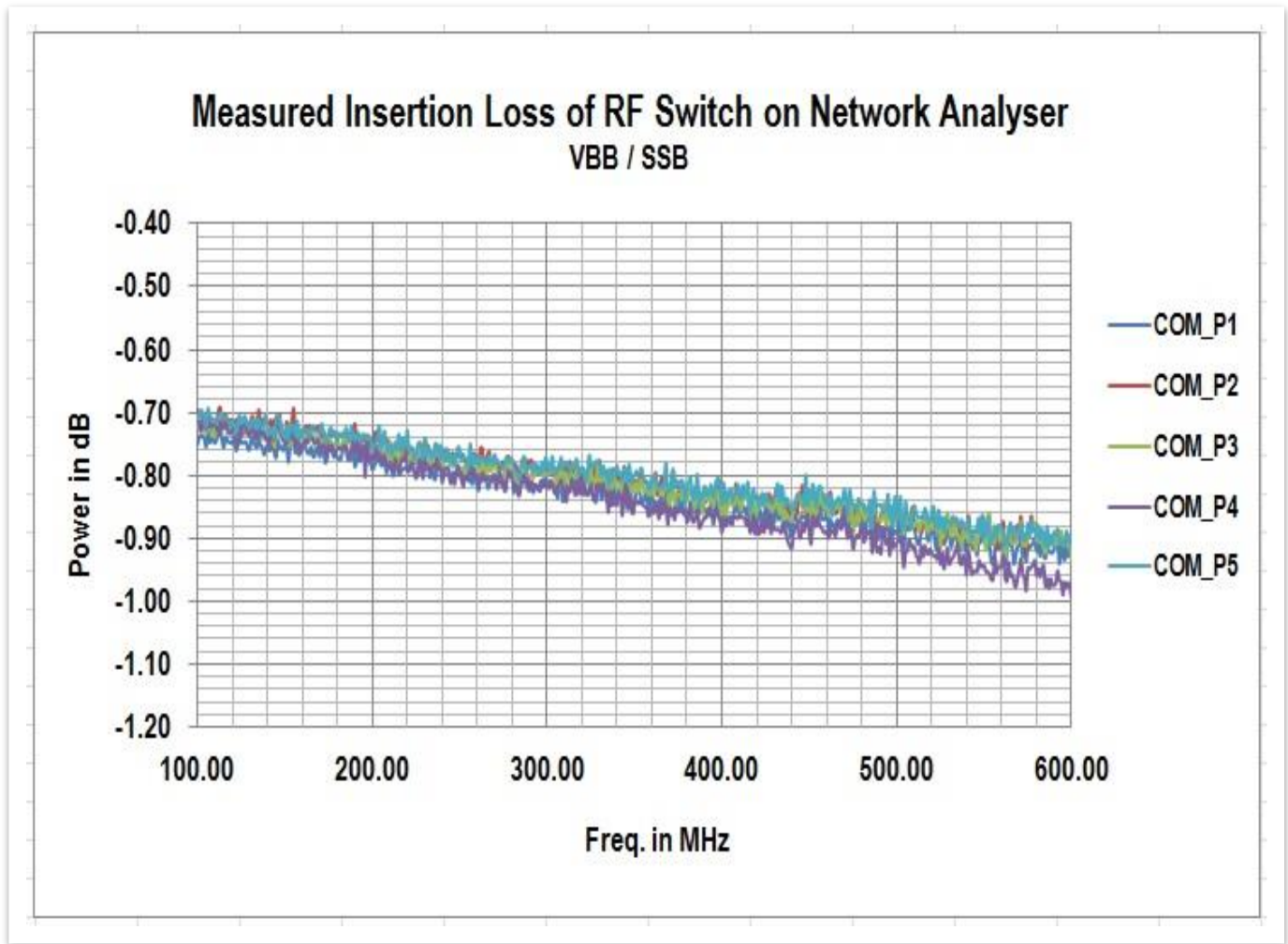

Figure 27(Insertion Loss between Common Port to P1,P2,P3,P4 and P5 Port)

SUMMARY REPORT OF SW6T RF SWITCH INSERTION LOSS

Parameters	Expected Loss	Loss at 250 MHz	Loss at 500 MHz
Common Port to Port 1	1.0 dB	0.7 dB	0.8 dB
Common Port to Port 2	1.0 dB	0.7 dB	0.8 dB
Common Port to Port 3	1.0 dB	0.7 dB	0.8 dB
Common Port to Port 4	1.0 dB	0.7 dB	0.8 dB
Common Port to Port 5	1.0 dB	0.7 dB	0.9 dB

10.1 SW6T RF SWITCH ISOLATION- P1 IS ON

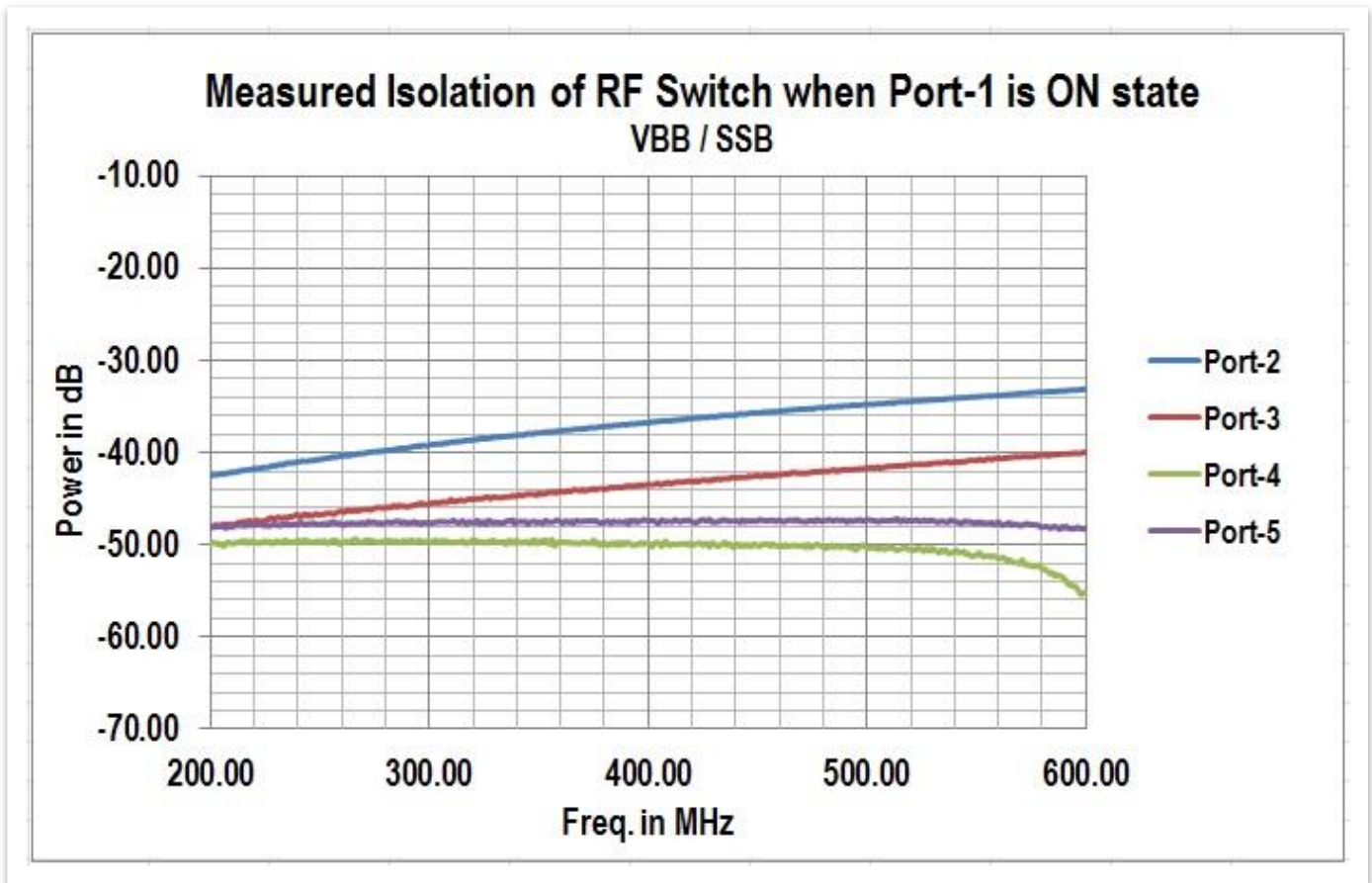

Figure 28(Isolation between Common Port to P2,P3,P4 and P5 Port when Port-1 is ON)

SUMMARY REPORT OF SW6T RF SWITCH ISOLATION- P1 IS ON

Parameters	Expected Isolation	Isolation at 250 MHz	Isolation at 500 MHz
Common Port to Port 2	30 dB	40.8 dB	34.9 dB
Common Port to Port 3	30 dB	46.8 dB	41.8 dB
Common Port to Port 4	30 dB	49.6 dB	49.4 dB
Common Port to Port 5	30 dB	47.6 dB	46.7 dB

10.2. SW6T RF SWITCH ISOLATION-P2 IS ON

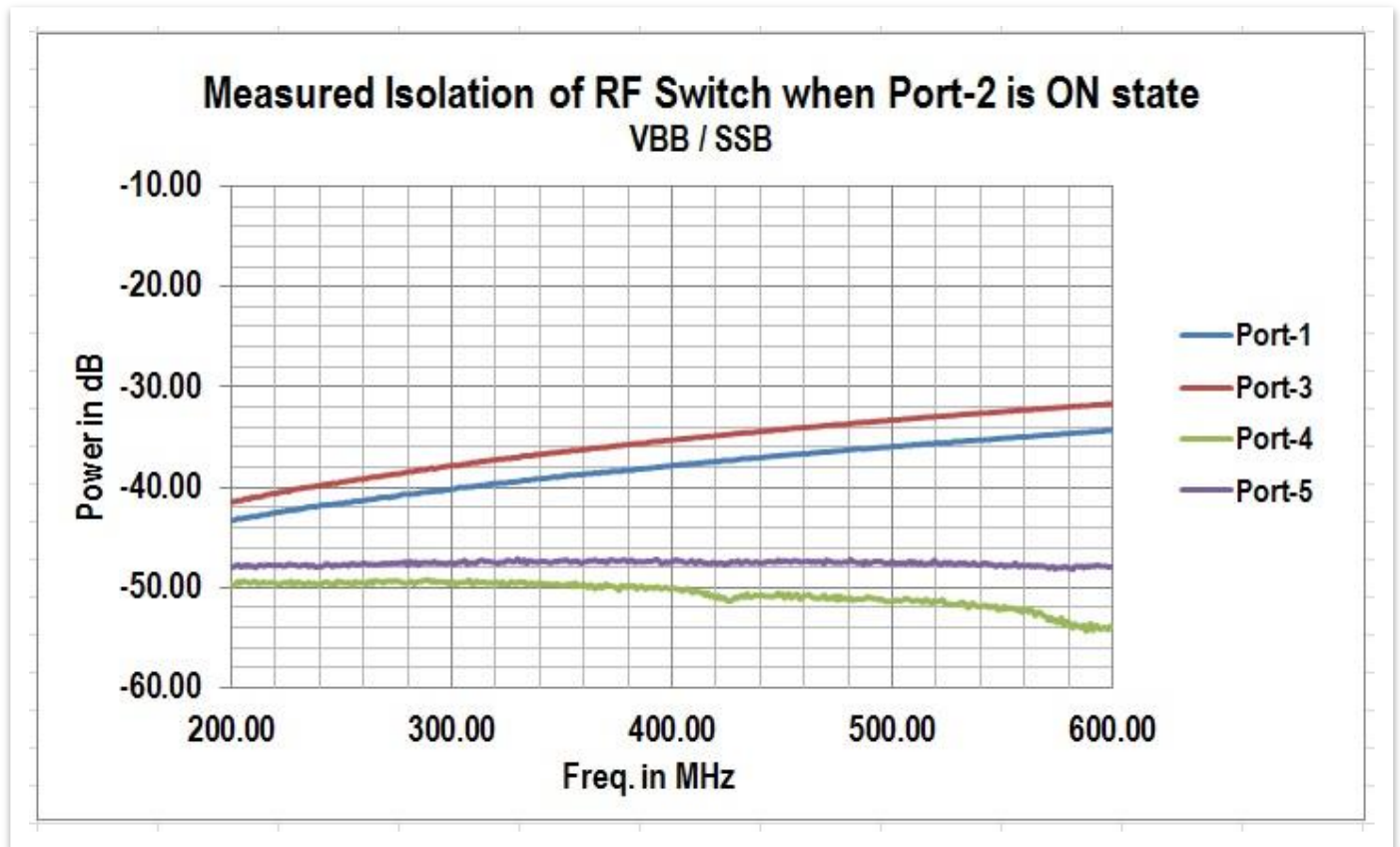

Figure 29(Isolation between Common Port to P1,P3,P4 and P5 Port when Port-2 is ON)

SUMMARY REPORT OF RF SWITCH ISOLATION-P2 IS ON

Parameters	Expected Isolation	Isolation at 250 MHz	Isolation at 500 MHz
Common Port to Port 1	30 dB	42.0 dB	36.5 dB
Common Port to Port 3	30 dB	39.9 dB	33.8 dB
Common Port to Port 4	30 dB	49.8 dB	50.3 dB
Common Port to Port 5	30 dB	47.7 dB	47.5 dB

10.3. SW6T RF SWITCH ISOLATION –P3 IS ON

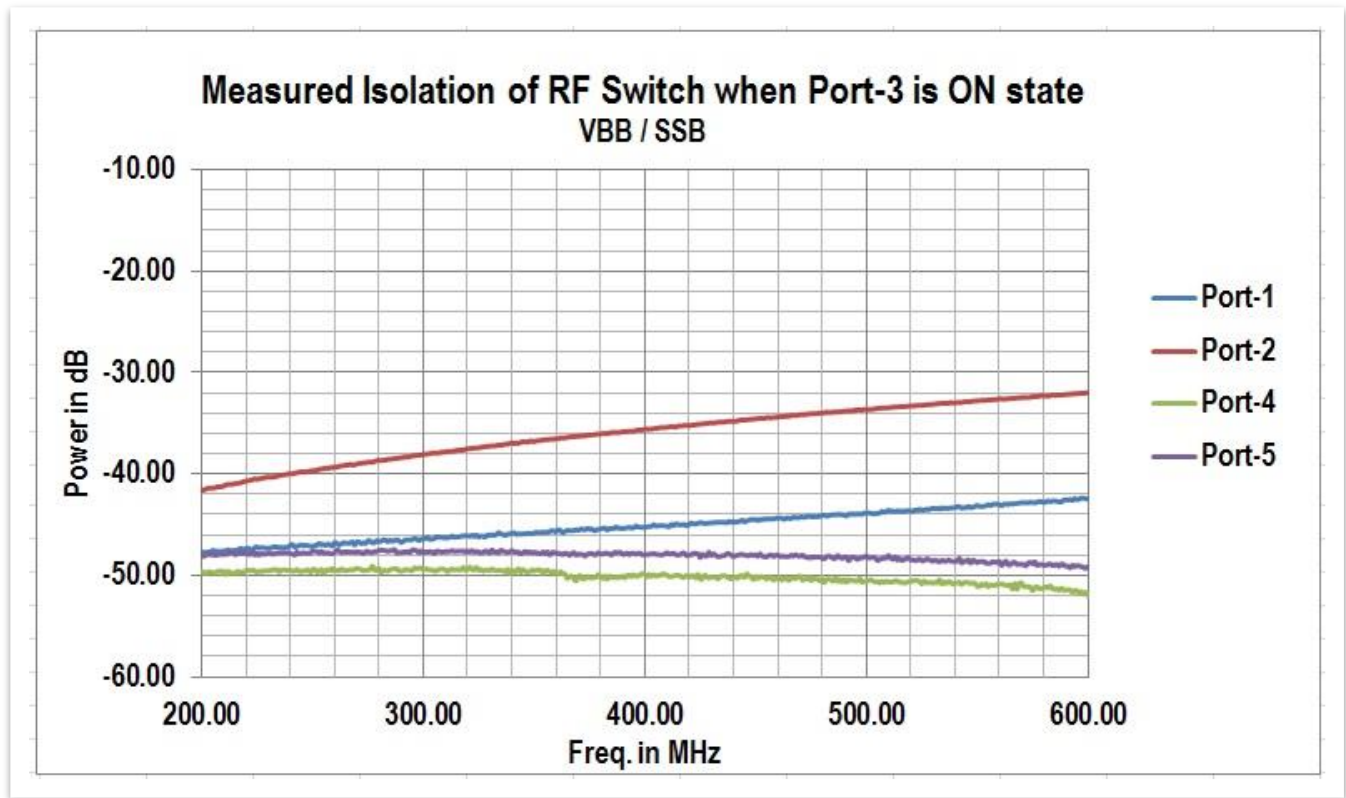

Figure 30 (Isolation between Common Port to P1,P2,P4 and P5 Port when Port-3 is ON)

SUMMARY REPORT OF SW6T RF SWITCH ISOLATION –P3 IS ON

Parameters	Expected Isolation	Isolation at 250 MHz	Isolation at 500 MHz
Common Port to Port 1	30 dB	47.7 dB	45.1 dB
Common Port to Port 2	30 dB	39.9 dB	33.9 dB
Common Port to Port 4	30 dB	49.8 dB	50.2 dB
Common Port to Port 5	30 dB	48.1 dB	48.6 dB

10.4. SW6T RF SWITCH ISOLATION –P4 IS ON

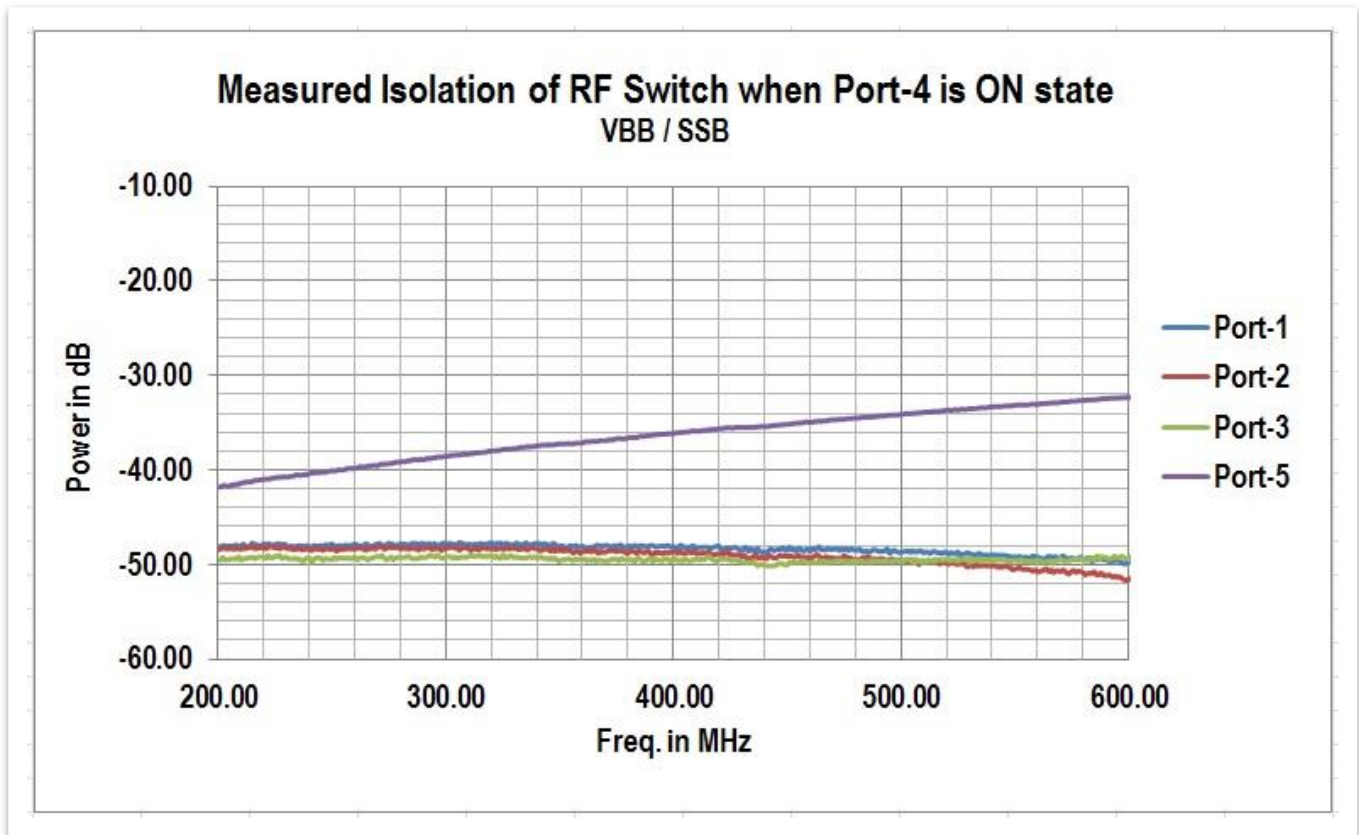

Figure 31 (Isolation between Common Port to P1,P2,P3 and P5 Port when Port-4 is ON)

SUMMARY REPORT OF SW6T RF SWITCH ISOLATION –P4 IS ON

Parameters	Expected Isolation	Isolation at 250 MHz	Isolation at 500 MHz
Common Port to Port 1	30 dB	48.2 dB	49.7 dB
Common Port to Port 2	30 dB	48.4 dB	50.2 dB
Common Port to Port 3	30 dB	49.6 dB	48.7 dB
Common Port to Port 5	30 dB	40.2 dB	33.7 dB

10.5. SW6T RF SWITCH ISOLATION –P5 IS ON

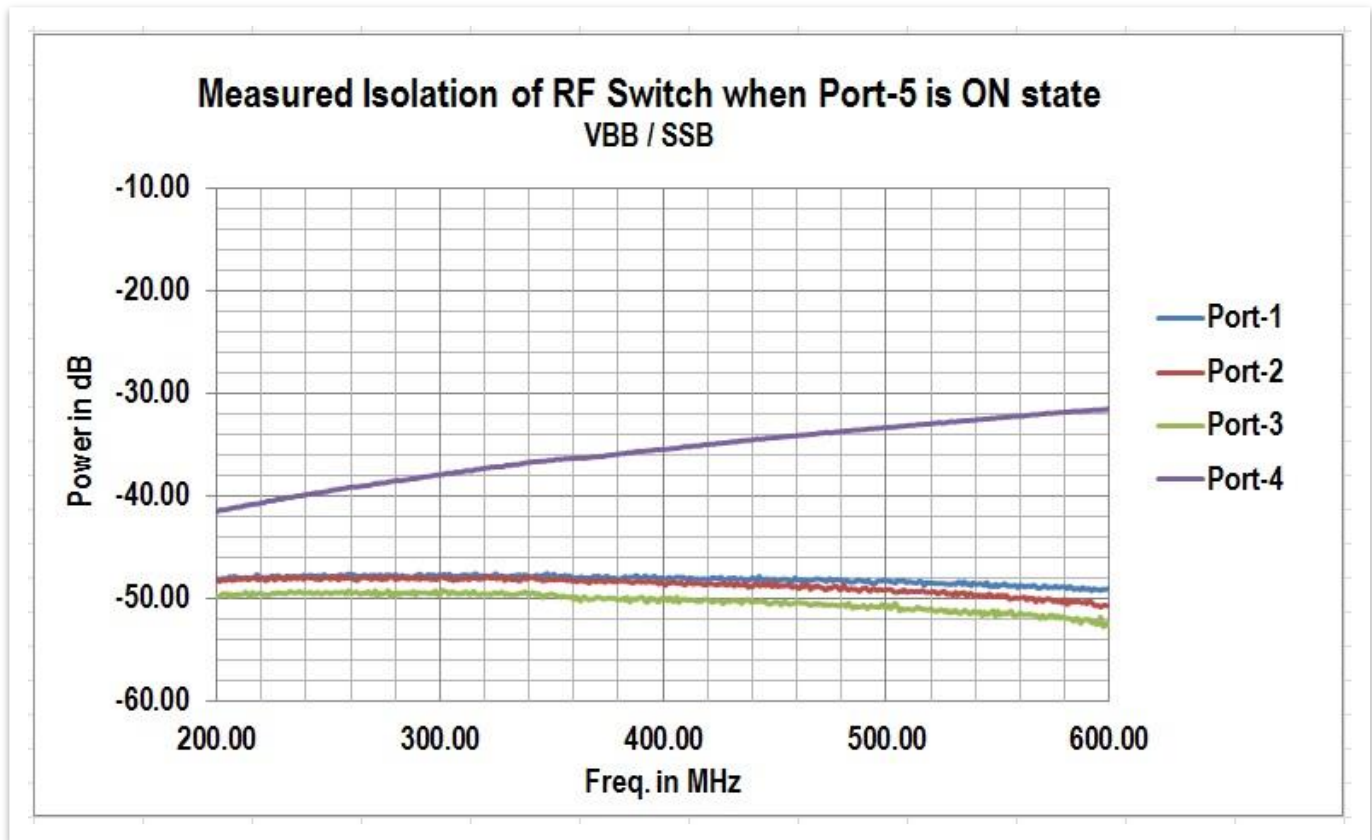

Figure 32 (Isolation between Common Port to P1,P2,P3 and P4 Port when Port-5 is ON)

SUMMARY REPORT OF SW6T RF SWITCH ISOLATION –P5 IS ON

Parameters	Expected Isolation	Isolation at 250 MHz	Isolation at 500 MHz
Common Port to Port 1	30 dB	48.2 dB	49.7 dB
Common Port to Port 2	30 dB	48.4 dB	50.2 dB
Common Port to Port 3	30 dB	49.6 dB	48.7 dB
Common Port to Port 4	30 dB	40.2 dB	33.7 dB

11. DEFLECTION MEASURED ON CYGA FOR ANTENNA C11 (250-500 MHz) FE BOX V-2 /VBB

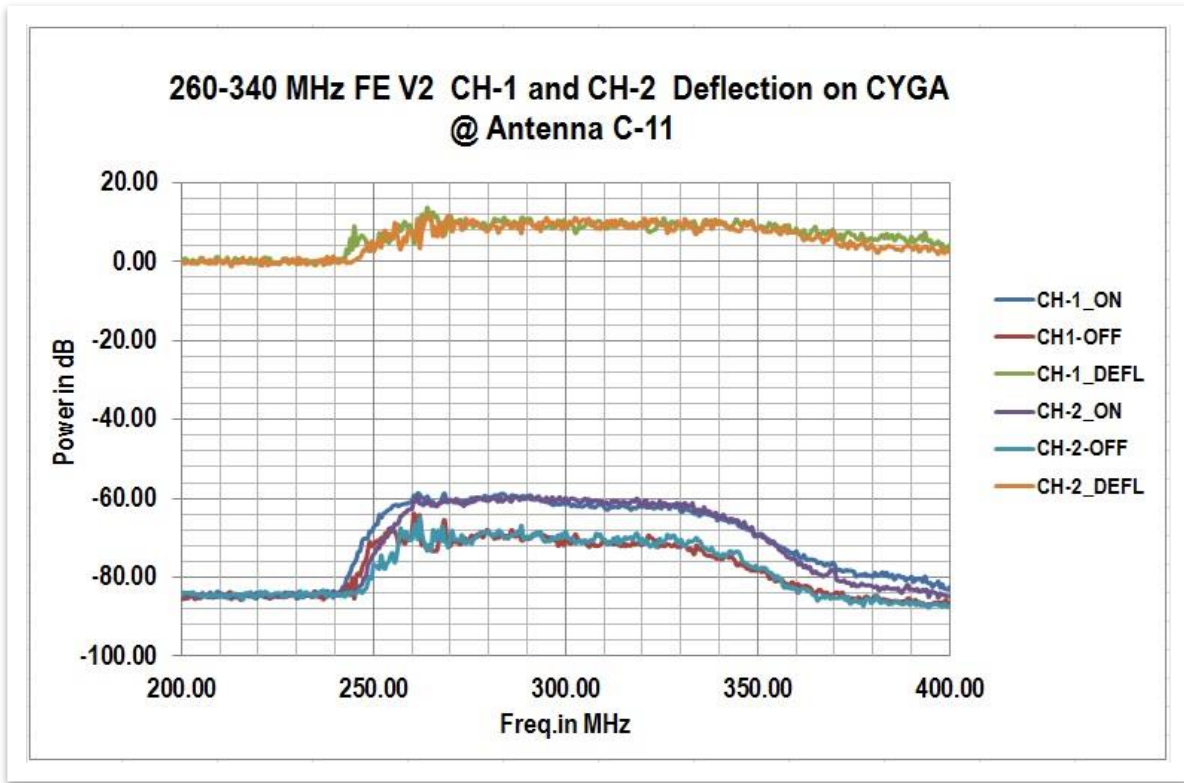

Figure 33 (CH-1 and CH-2 260-340 MHz CYGA Deflection at Antenna base)

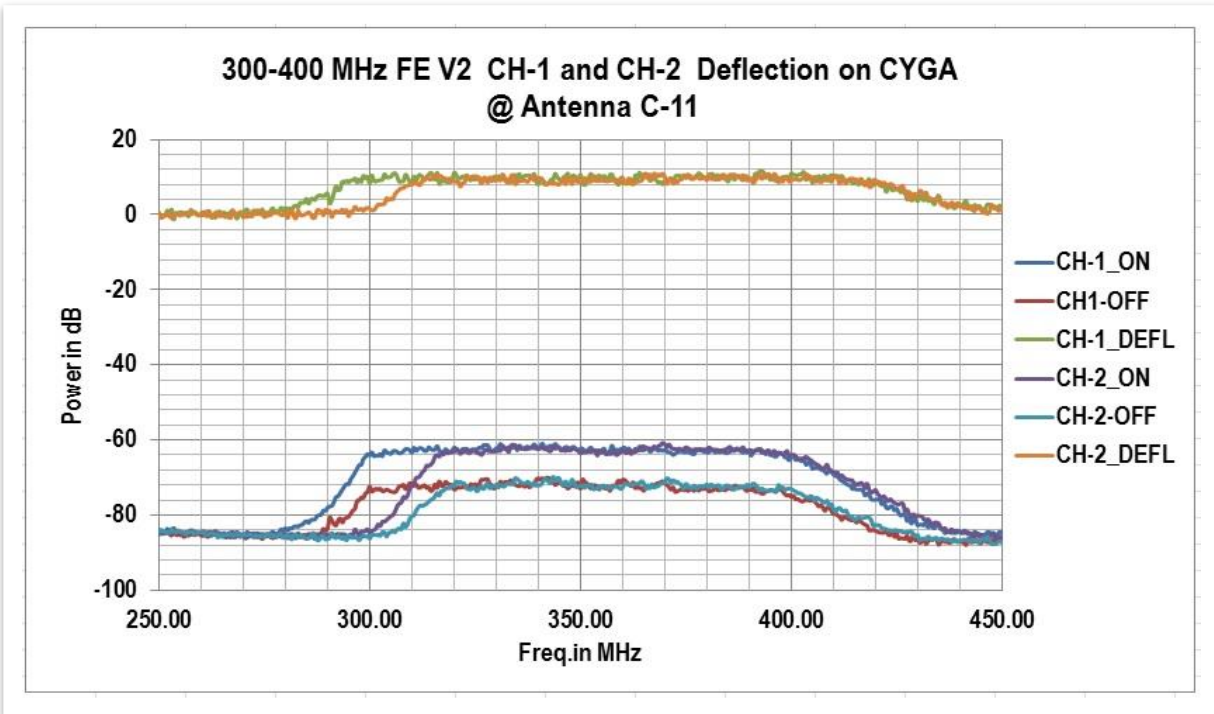

Figure 34 (CH-1 and CH-2 300-400 MHz CYGA Deflection at Antenna base with some offset)

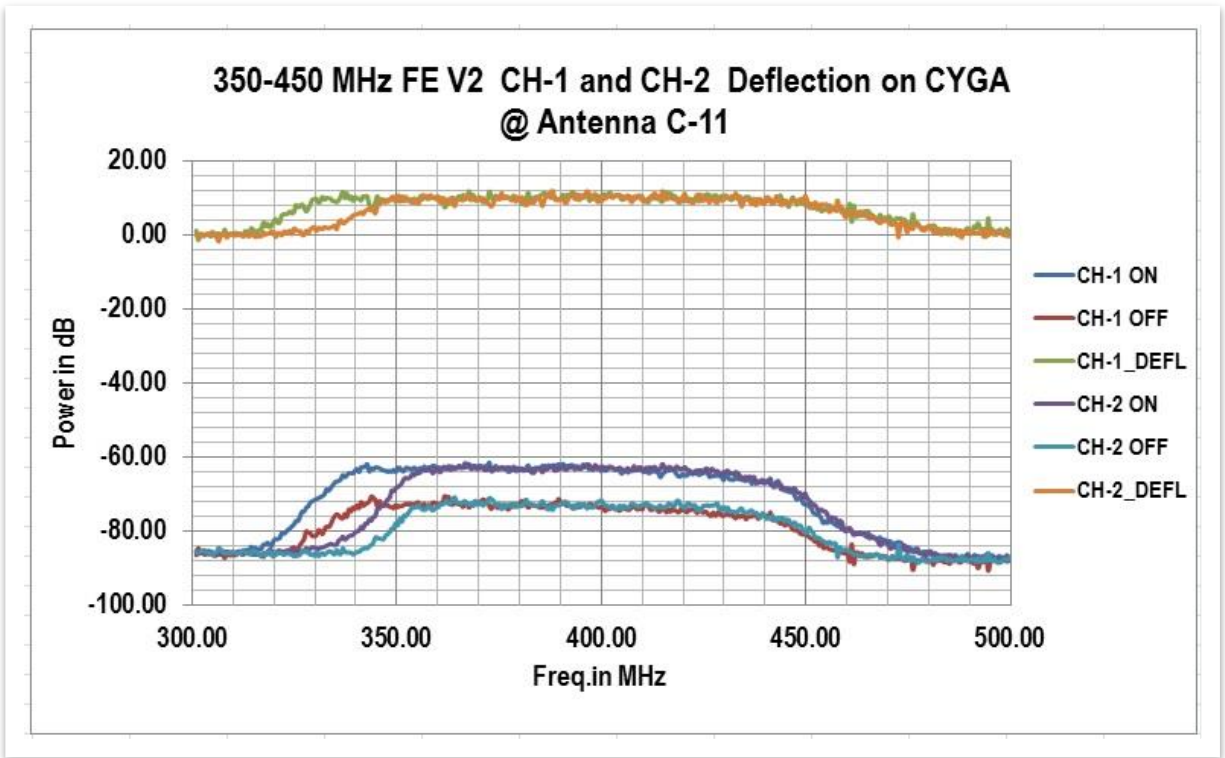

Figure 35 (CH-1 and CH-2 340-450 MHz CYGA Deflection at Antenna base with some offset)

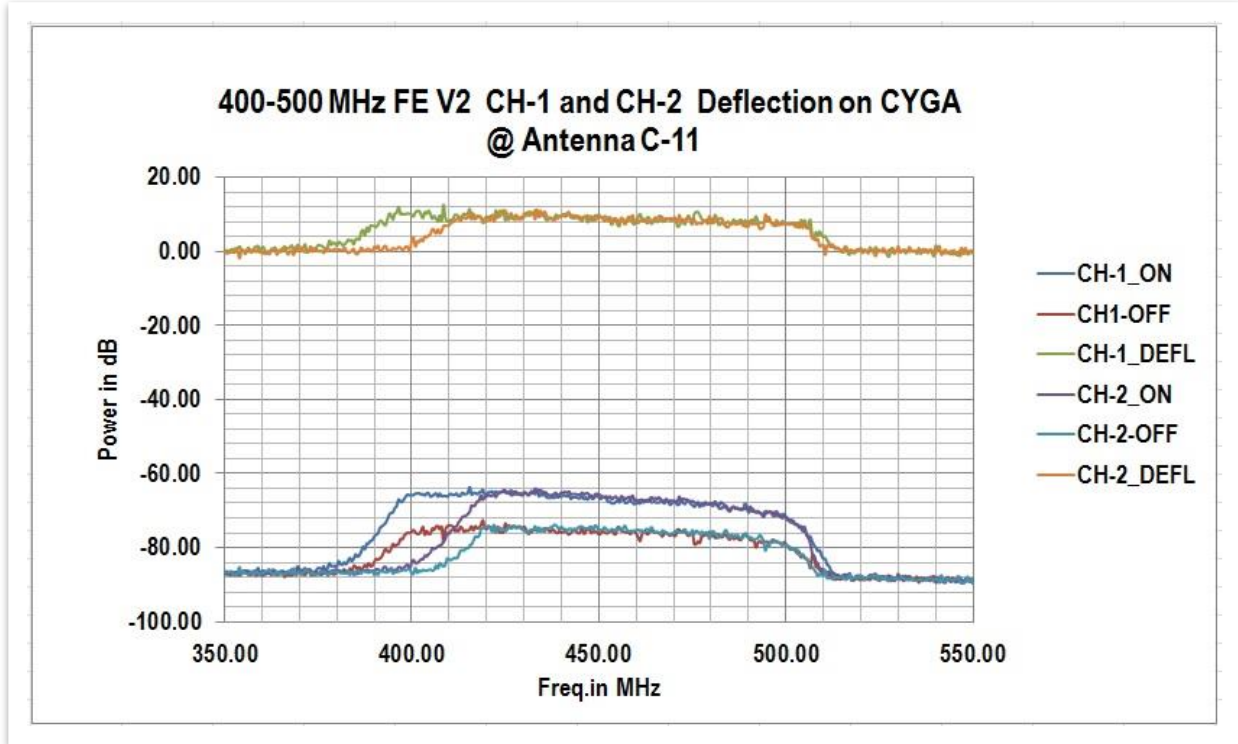

Figure 36(CH-1 and CH-2 400-500 MHz CYGA Deflection at Antenna base with some offset)

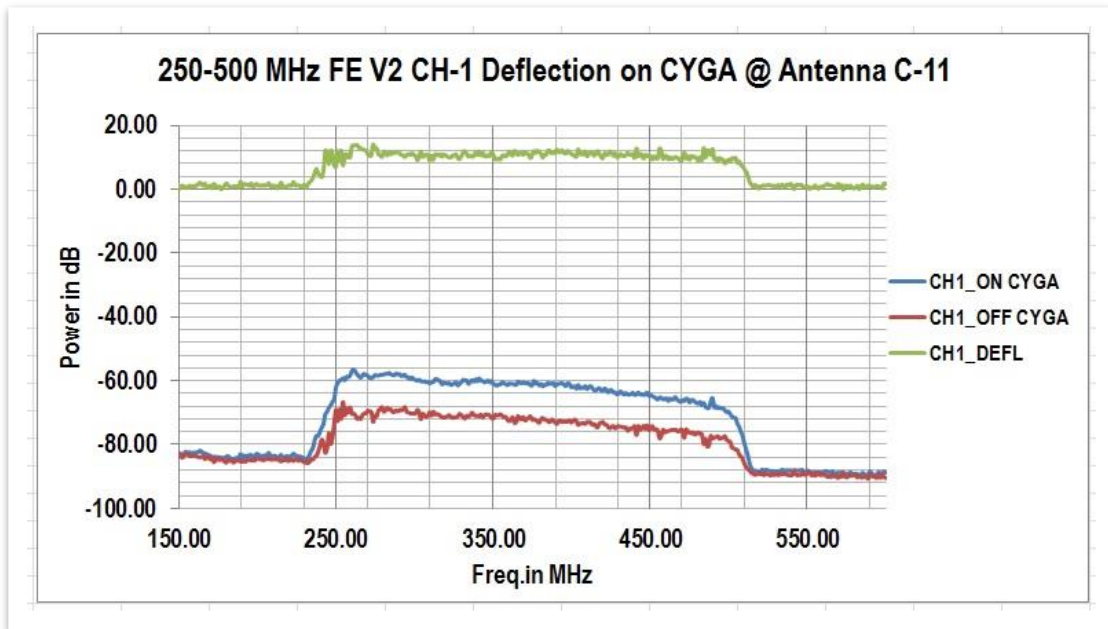

Figure 37 (CH-1 250-500 MHz CYGA Deflection at Antenna base)

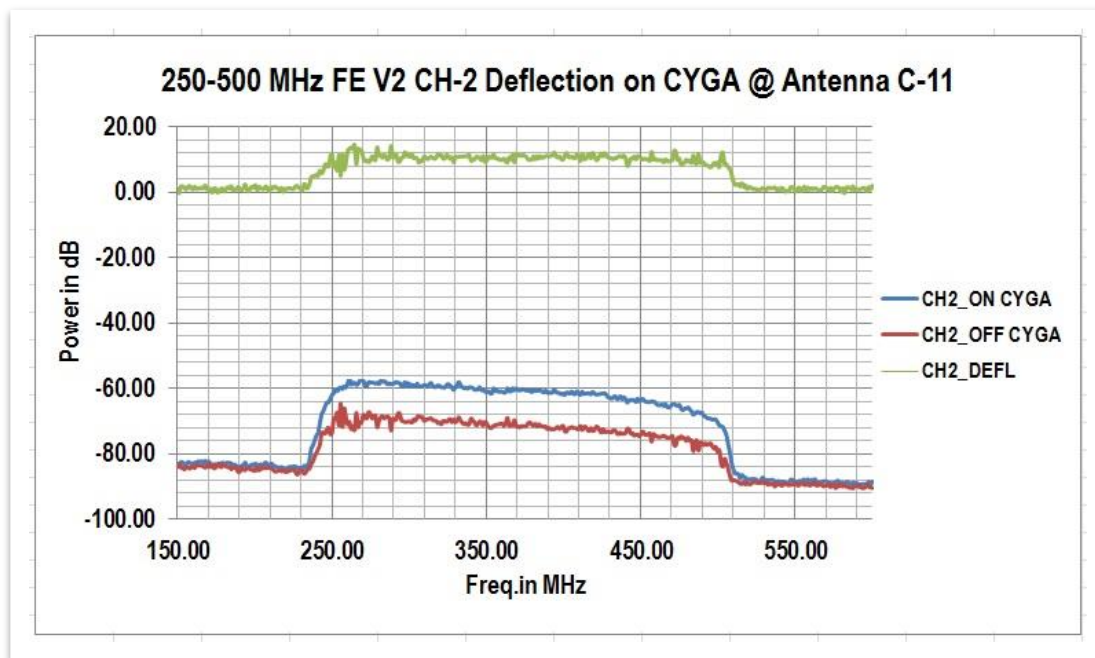

Figure 38 (CH-2 250-500 MHz CYGA Deflection at Antenna base)

SUMMARY REPORT OF DEFLECTION AT C11 ON CYGA

Frequency Band in MHz	CH-1 Deflection in dB	CH-2 Deflection in dB	Expected deflection on CYGA in dB
250-500	11.35	11.38	12.4

12. NOISE DEFLECTION MEASURED AT ANTENNA BASE C11 (250-500 MHz) FE BOX V-2 VBB

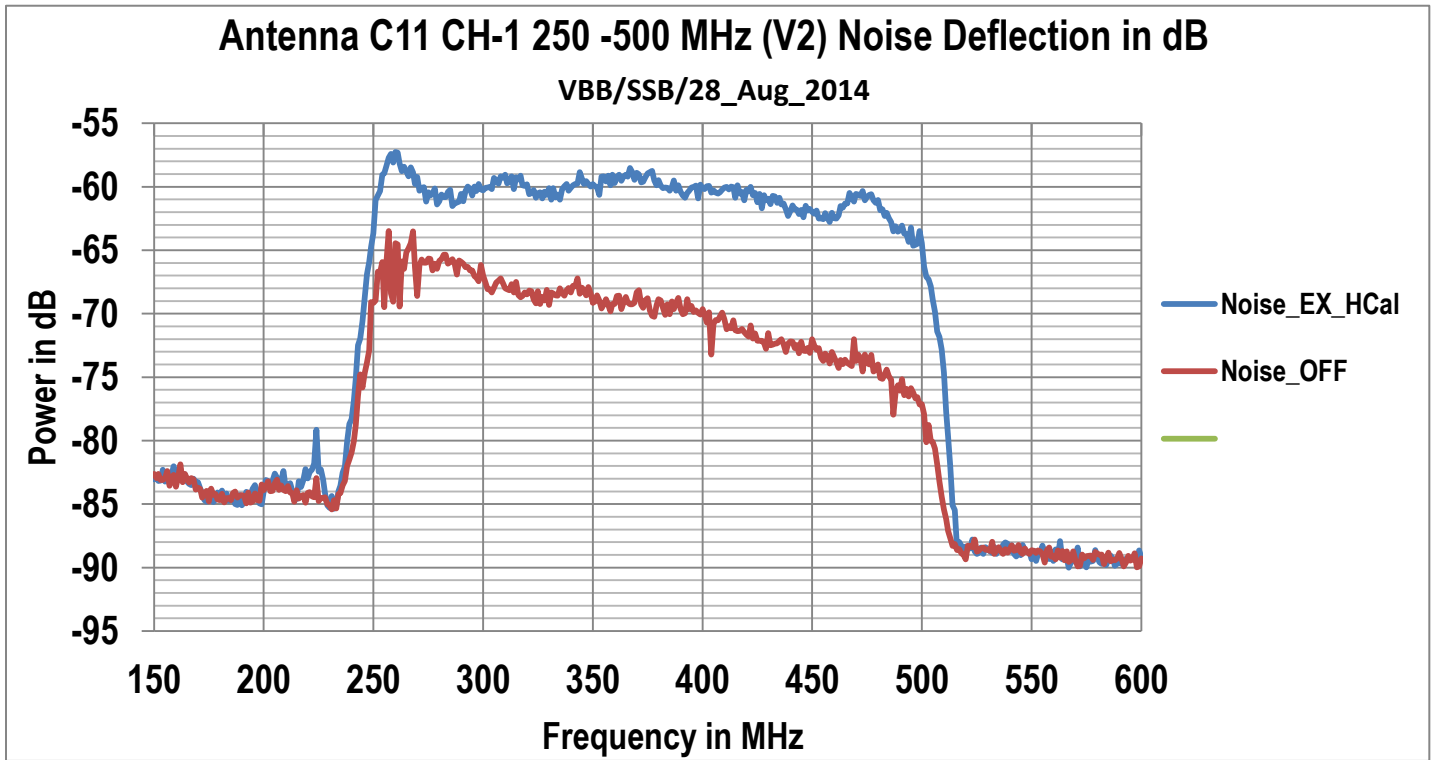

Figure 39 (CH-1 260-340 MHz NOISE Deflection)

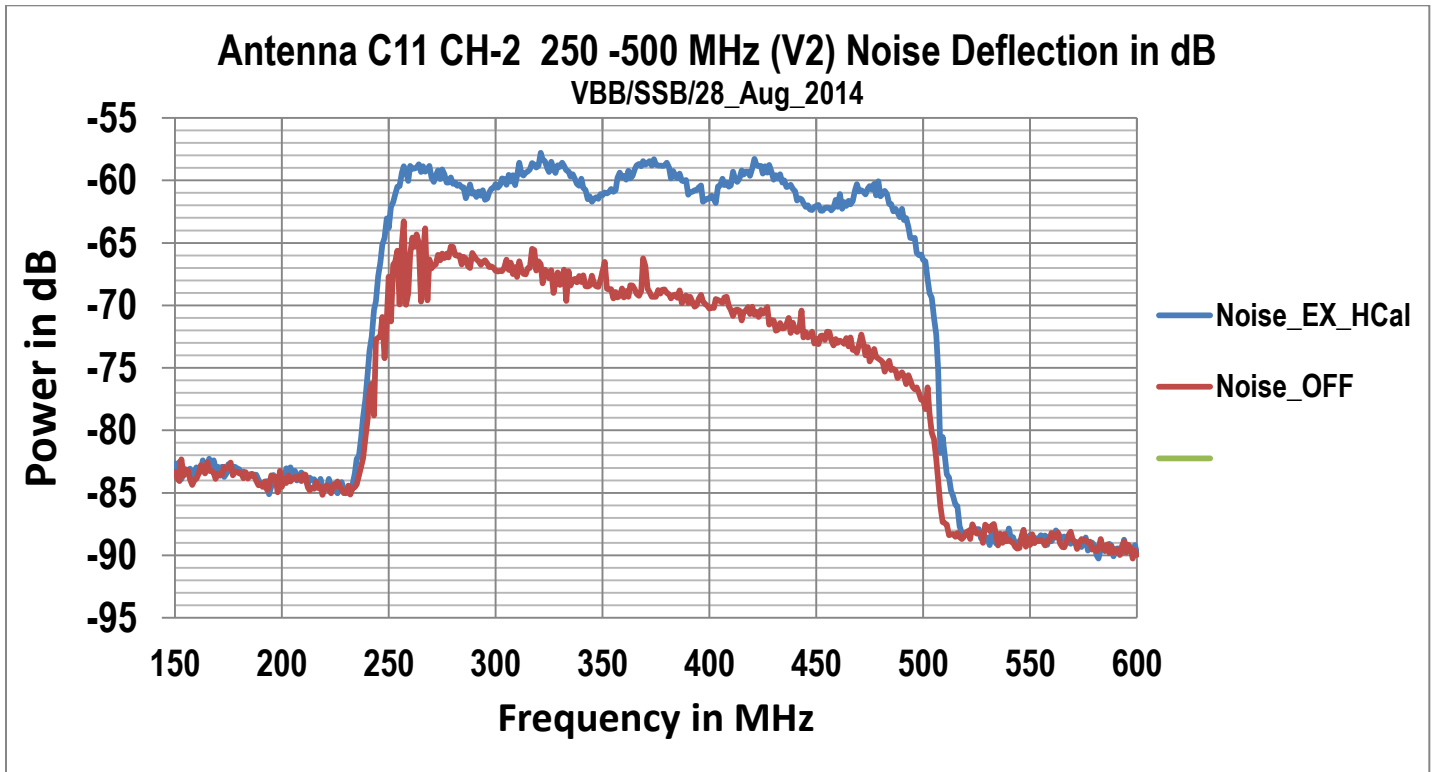

Figure 40 (CH-2 260-340 MHz NOISE Deflection)

Antenna C11 CH-1 260 - 340 MHz (V2) Noise Deflection in dB
VBB/SSB/28_Aug_2014

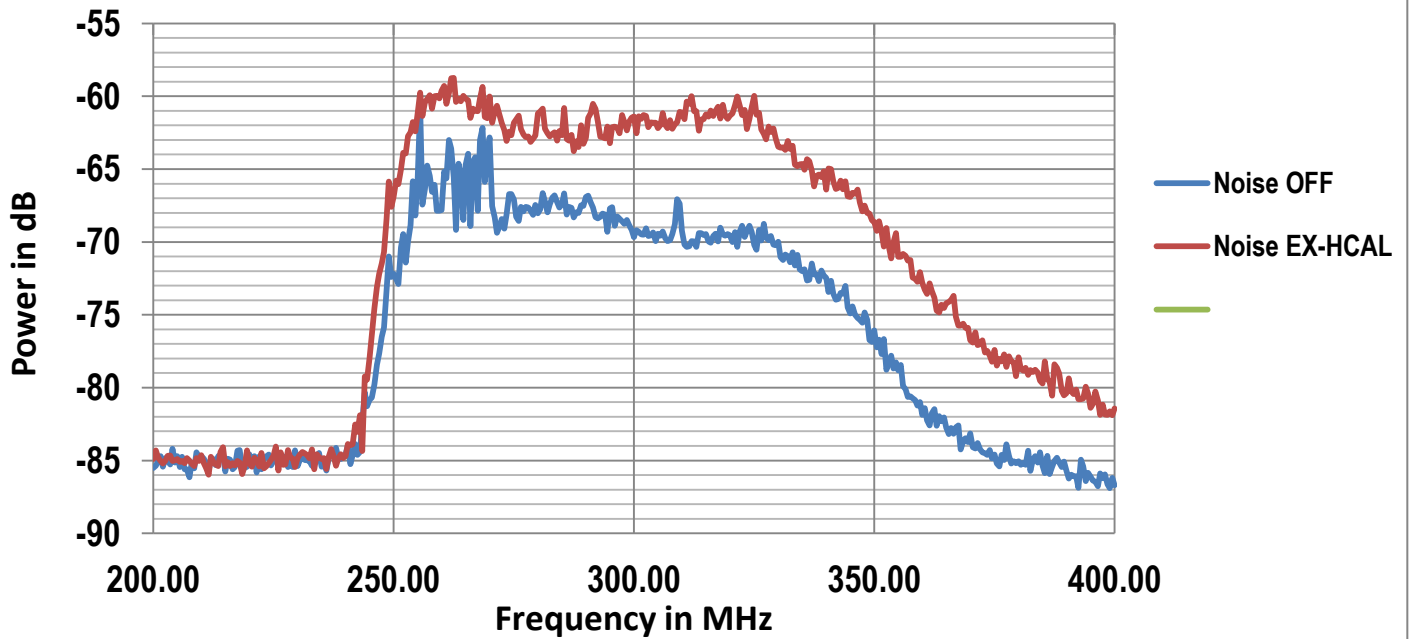

Figure 41 (CH-1 260-340 MHz NOISE Deflection)

Antenna C11 CH-1 300-400 MHz (V2) Noise Deflection in dB
VBB/SSB/28_Aug_2014

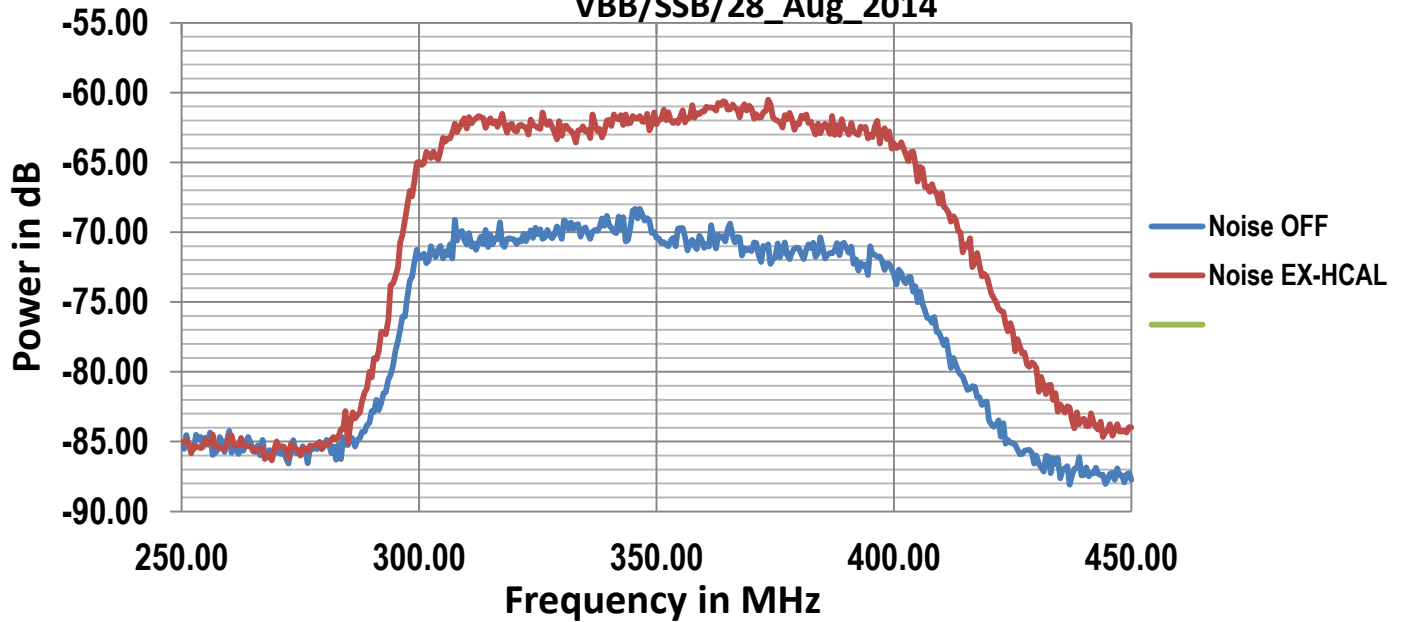

Figure 42 (CH-1 300-400 MHz NOISE Deflection)

Antenna C11 CH-1 350 - 450 MHz (V2) Noise Deflection in dB
VBB/SSB/28_Aug_2014

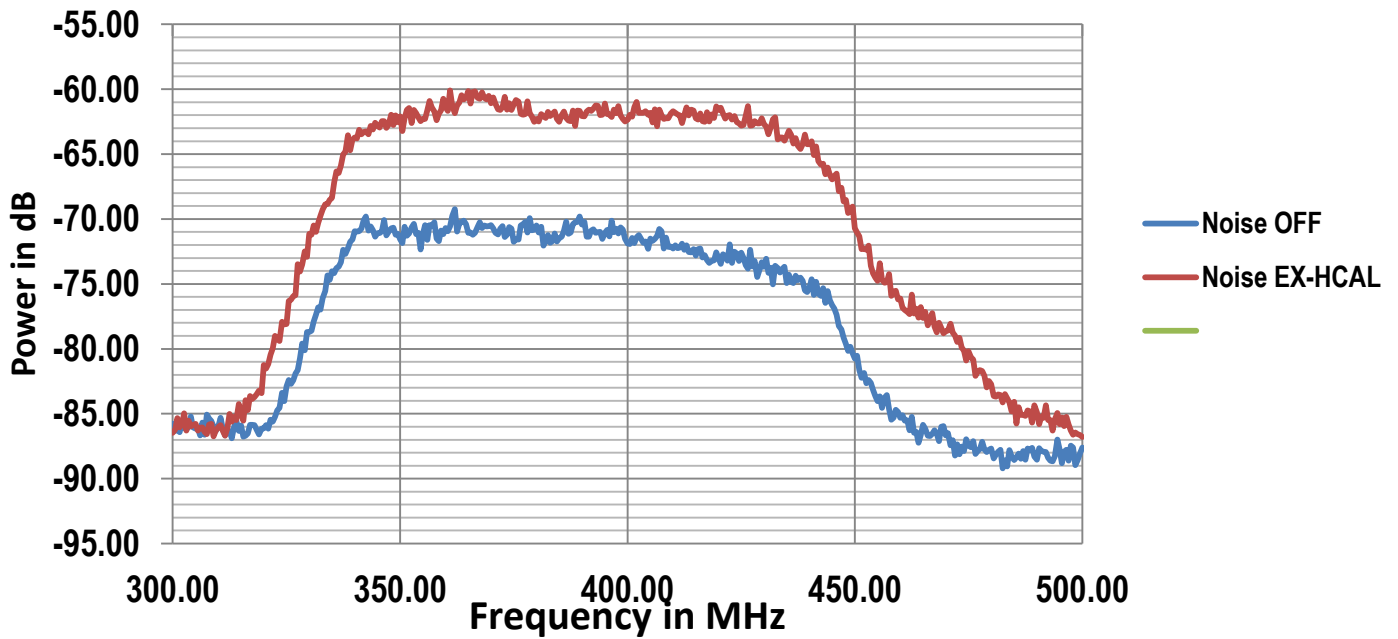

Figure 43 (CH-1 350-450 MHz NOISE Deflection)

Antenna C11 CH-1 400 - 500 MHz (V2) Noise Deflection in dB
VBB/SSB/28_Aug_2014

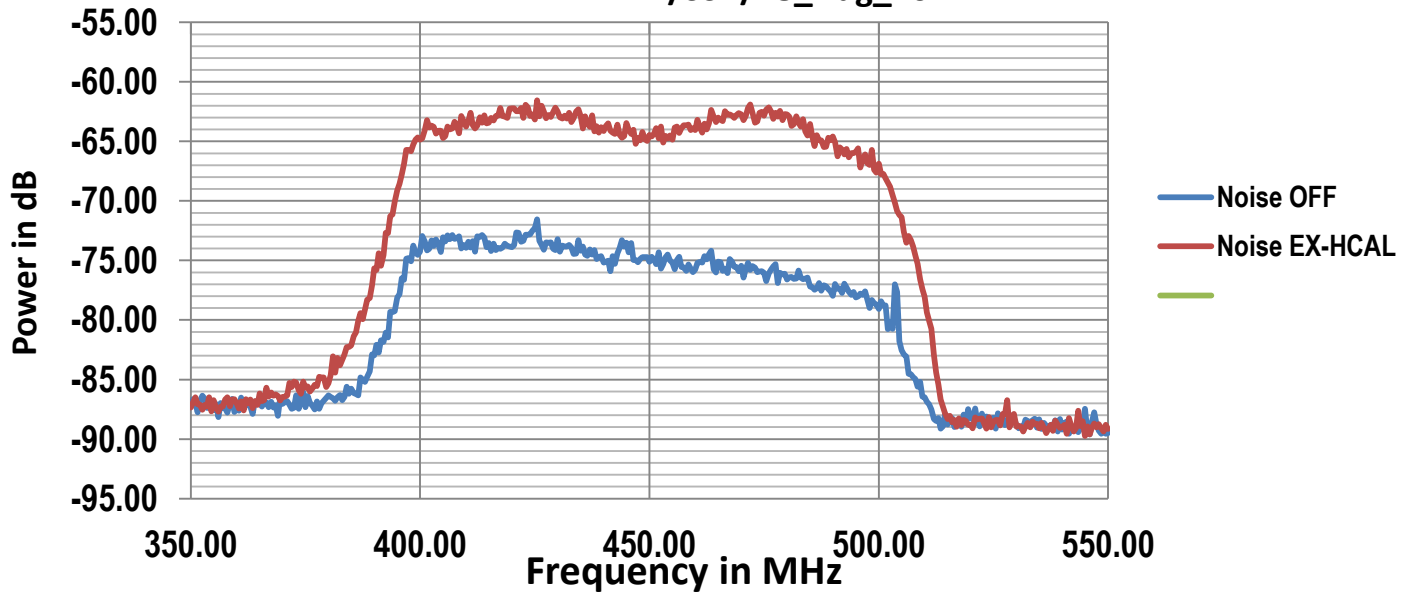

Figure 44 (CH-1 400-500 MHz NOISE Deflection)

Antenna C11 CH-2 260 - 340 MHz (V2) Noise Deflection in dB VBB/SSB/28_Aug_2014

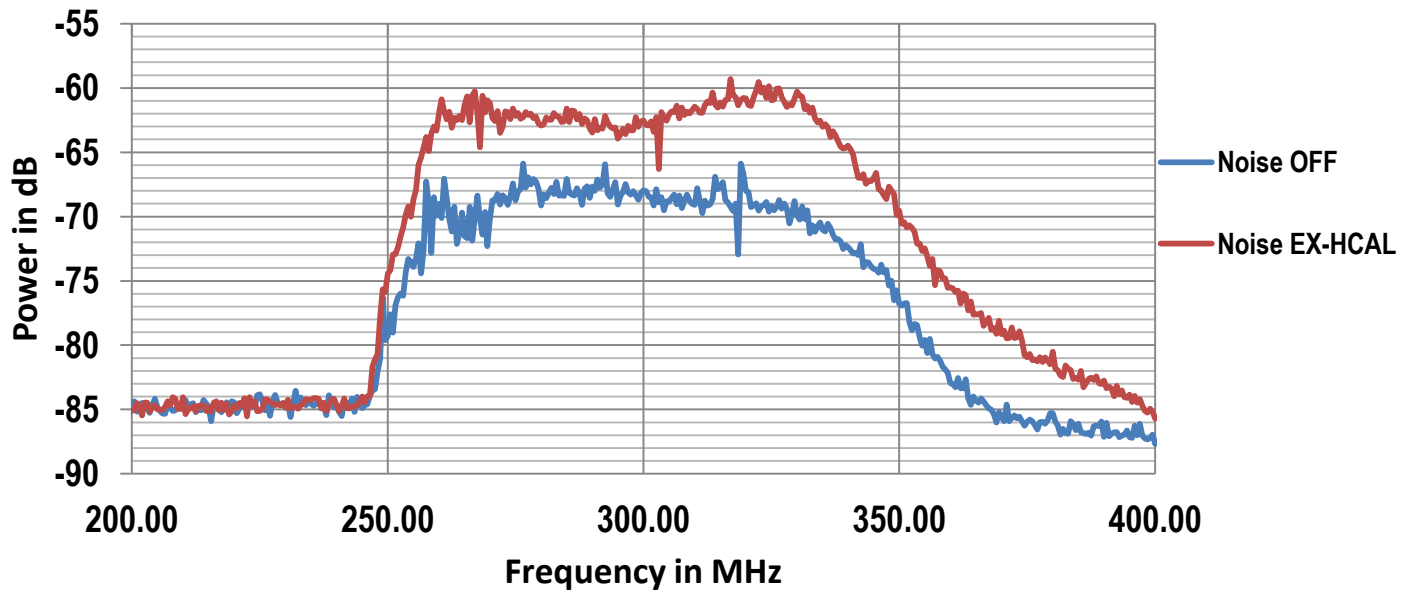

Figure 45 (CH-2 260-340 MHz NOISE Deflection)

Antenna C11 CH-2 300-400 MHz (V2) Noise Deflection in dB VBB/SSB/28_Aug_2014

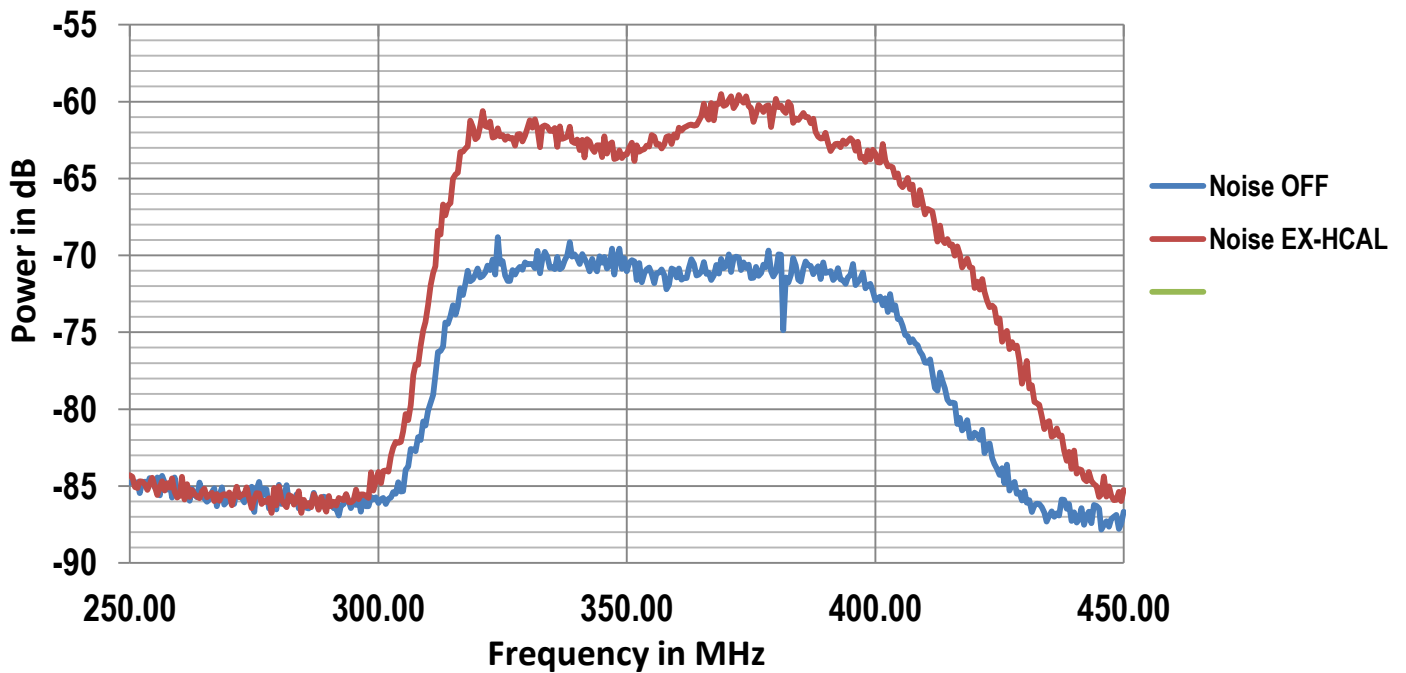

Figure 46 (CH-2 300-400 MHz NOISE Deflection)

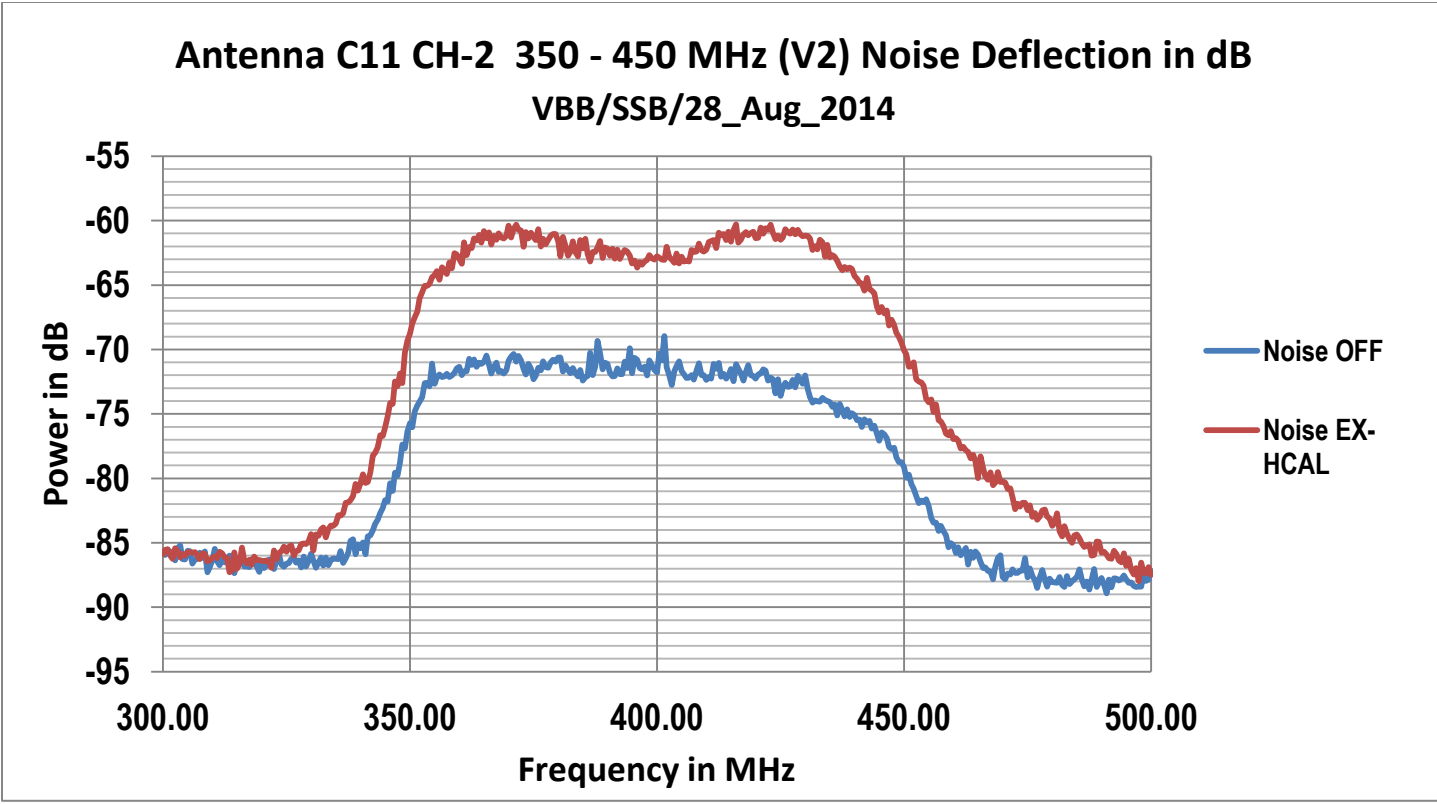

Figure 47 (CH-2 350-450 MHz NOISE Deflection)

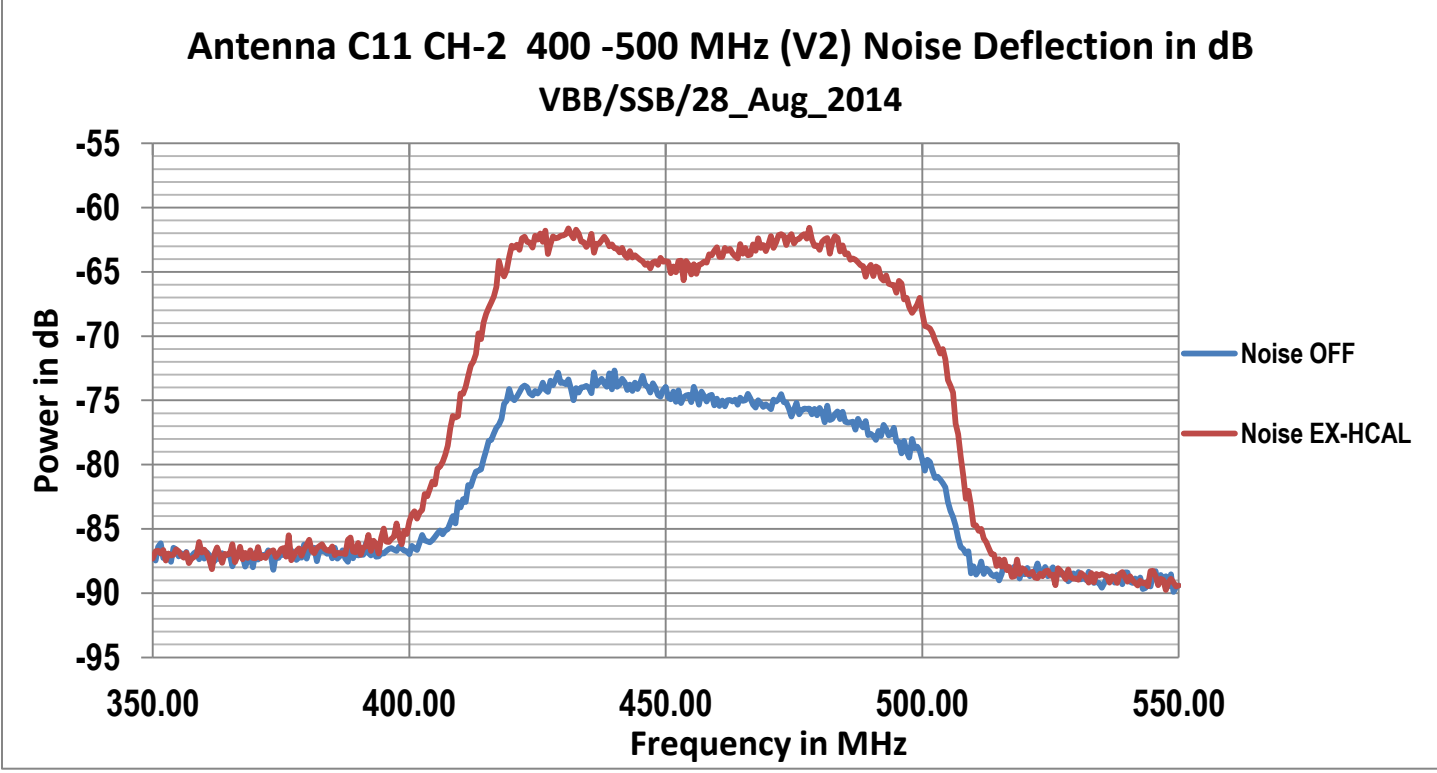

Figure 48 (CH-2 400-500 MHz NOISE Deflection)

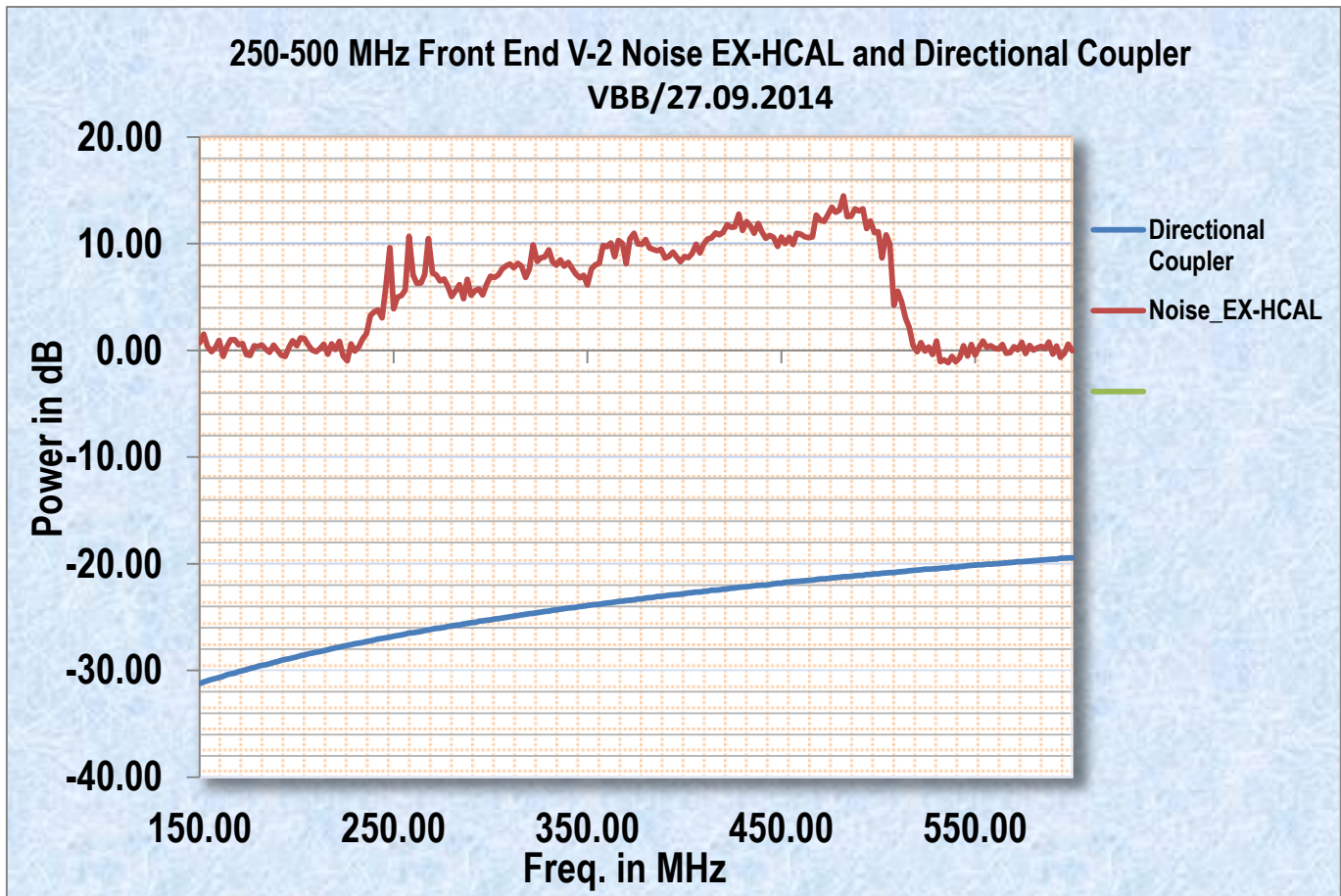
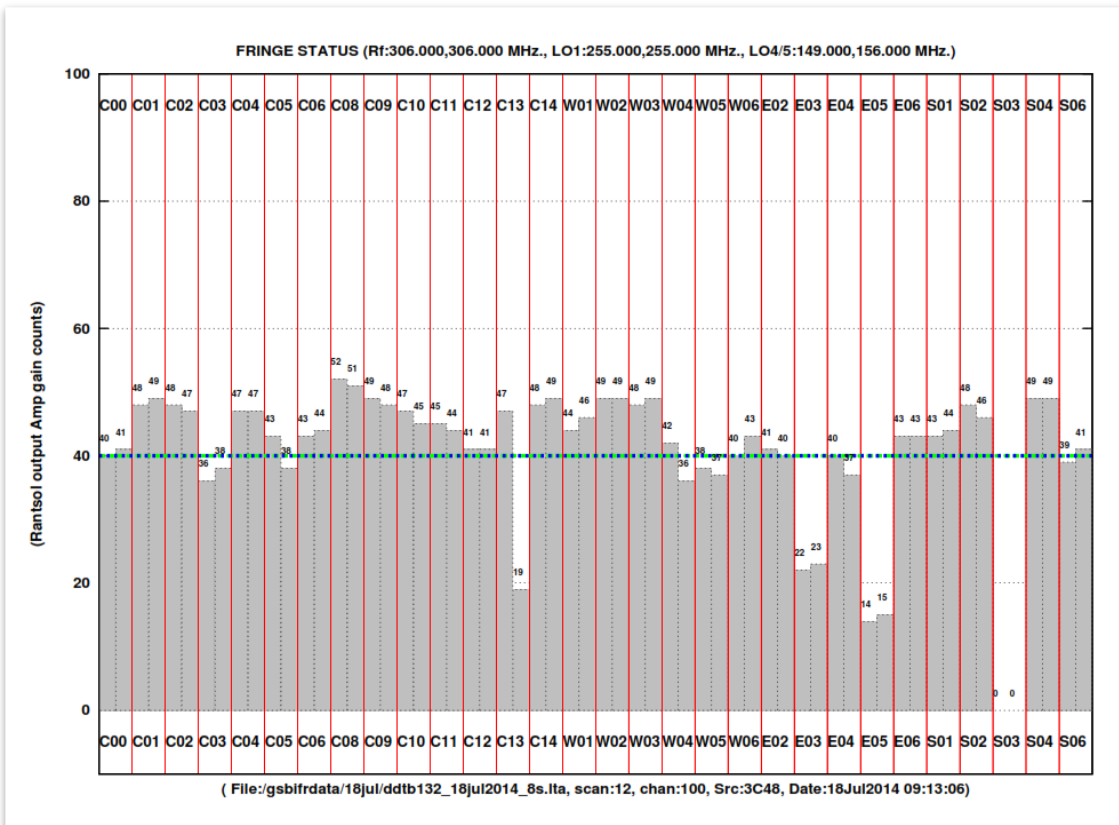
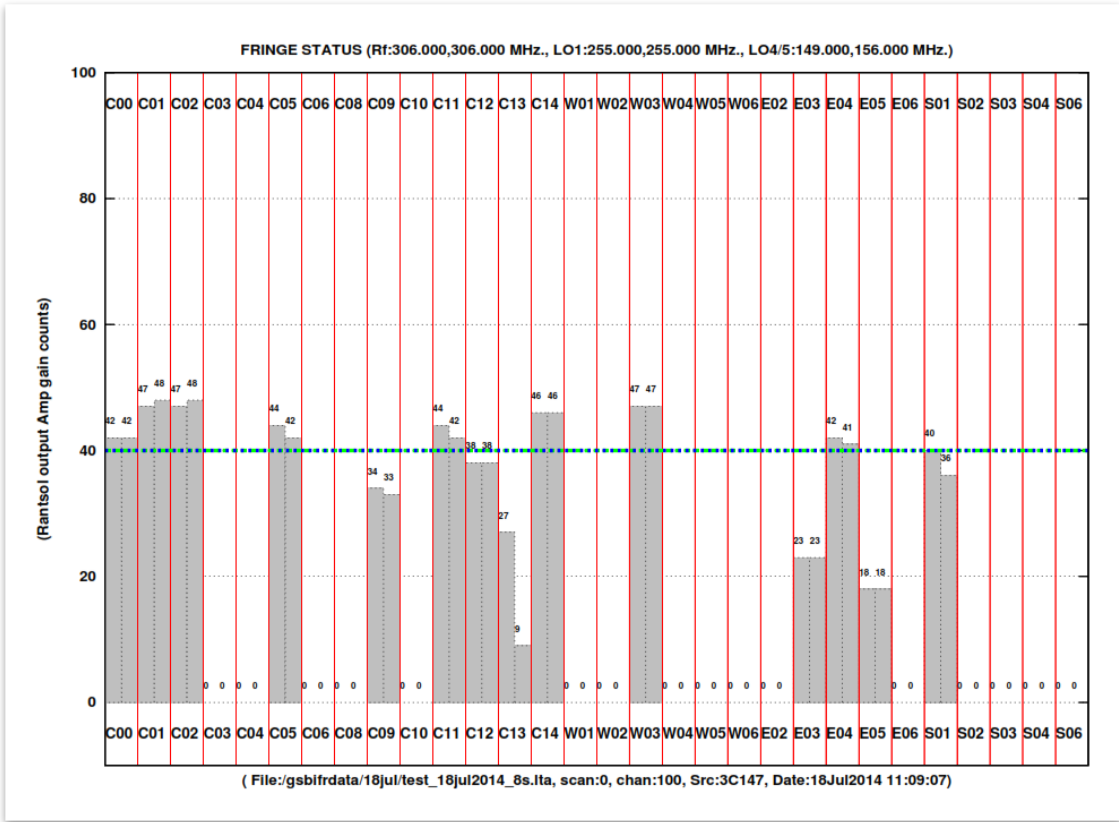

Figure 49 (250-500 MHz NOISE Deflection and Noise Coupling (Directional Coupler)).

SUMMARY REPORT OF NOISE DEFLECTION AT C11

- There is slope of 7 dB in Directional Coupler from 250 – 500 MHz band (-27 dB at 250 MHz and -20 dB at 500 MHz).
- The Noise deflection is 5 dB at 250 MHz and it is gradually increase up-to 12 dB at 500 MHz.
- The Noise generator power is almost constant around 32 dB for entire 250 -500 MHz band.
- The Noise deflection is 5 – 6 dB for 260 – 340 MHz sub band.
- The Noise deflection is 8 – 9 dB for 300 – 400 MHz sub band.
- The Noise deflection is 9 – 10 dB for 350 – 450 MHz sub band.
- The Noise deflection is 10 – 12 dB for 400 – 500 MHz sub band.

13. FRINGE STATUS OF FE BOX 250-500 MHz V-2 INSTALL ON C-11



14. PHOTOGRAPH OF FE BOX 250-500 MHz V-2

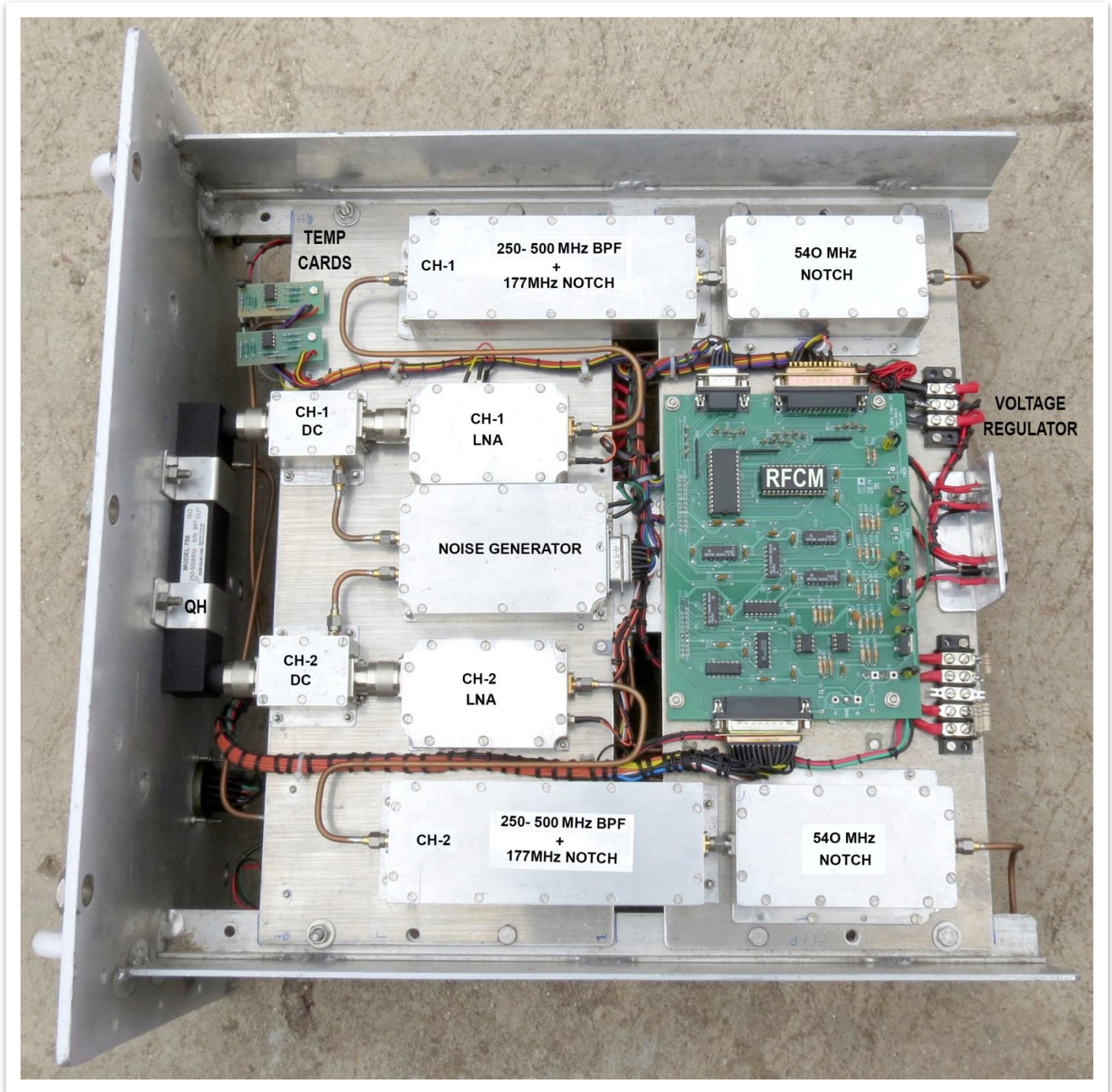

Figure 50 (Top View of 250-500 MHz FE Box Ver-2)

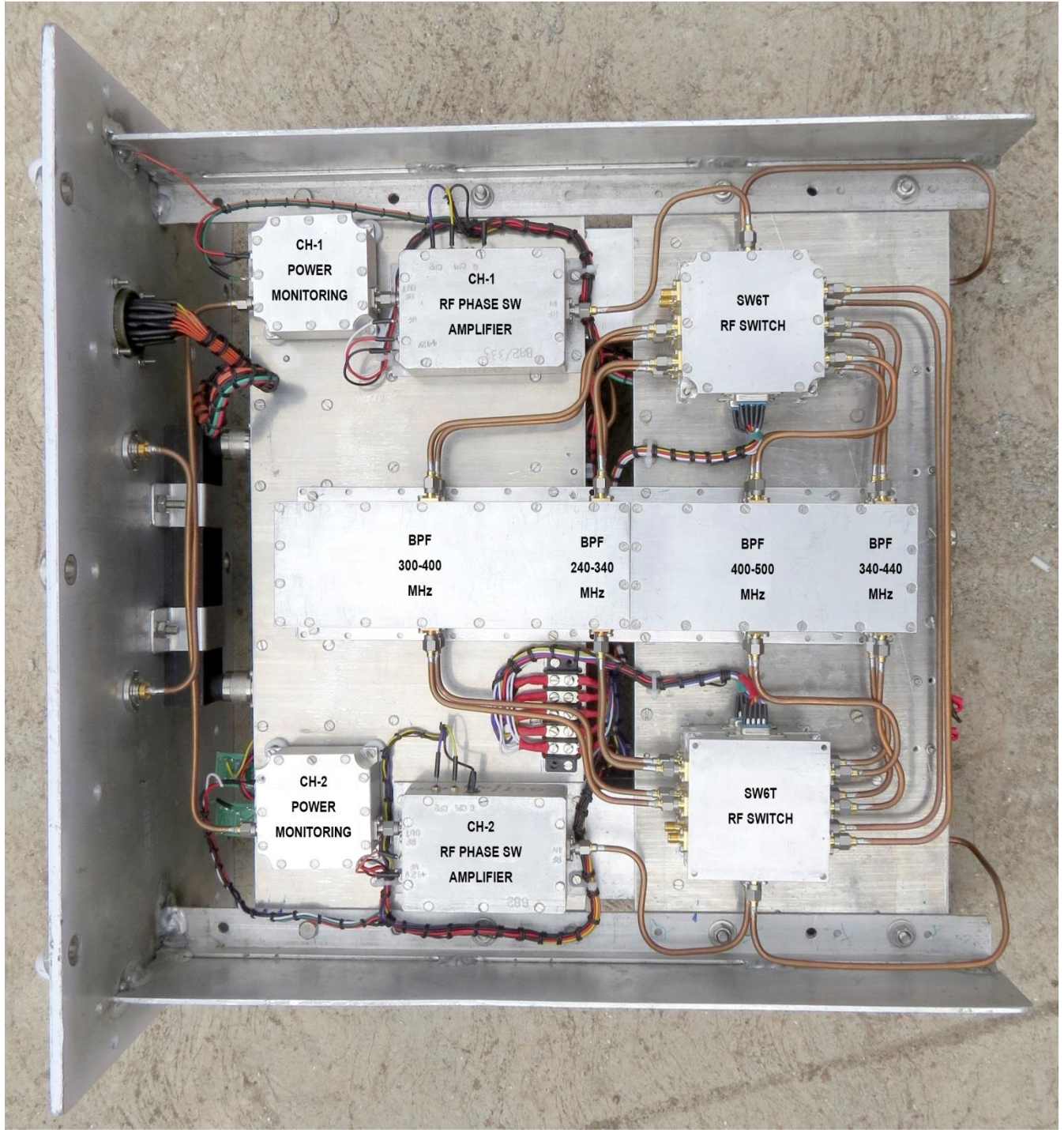

Figure 51 (Bottom View of 250-500 MHz FE Box Ver-2)

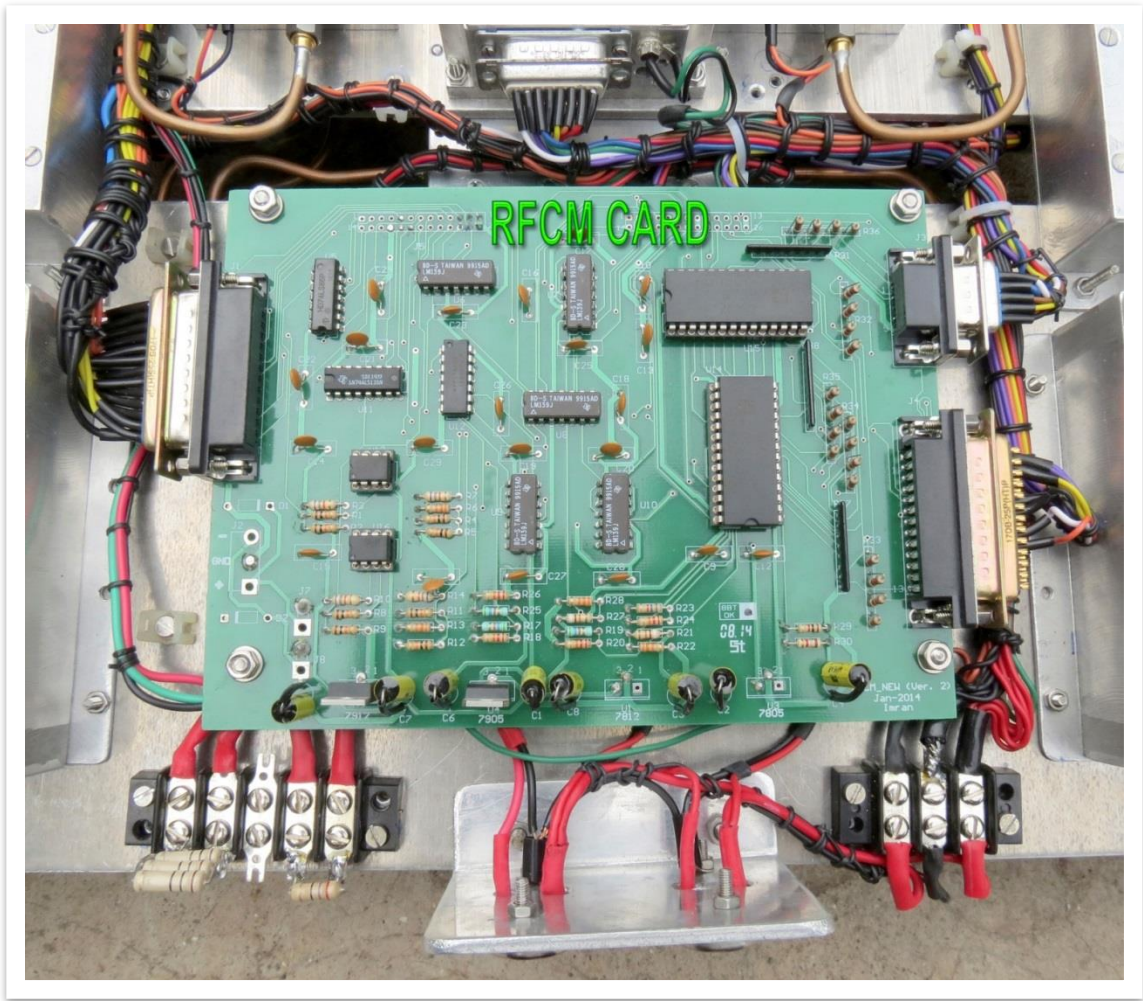

Figure 52 (New RFCM CARD)

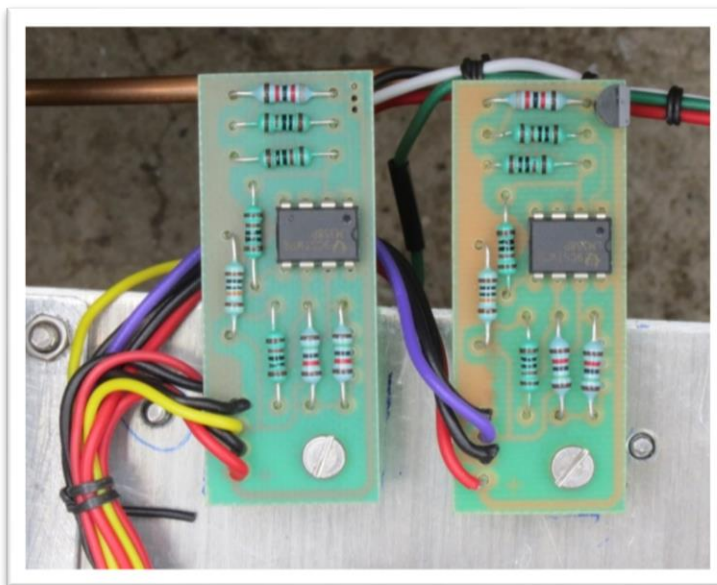

Figure 53 (Two Temperature Monitoring Units for inside LNA and FE Box)

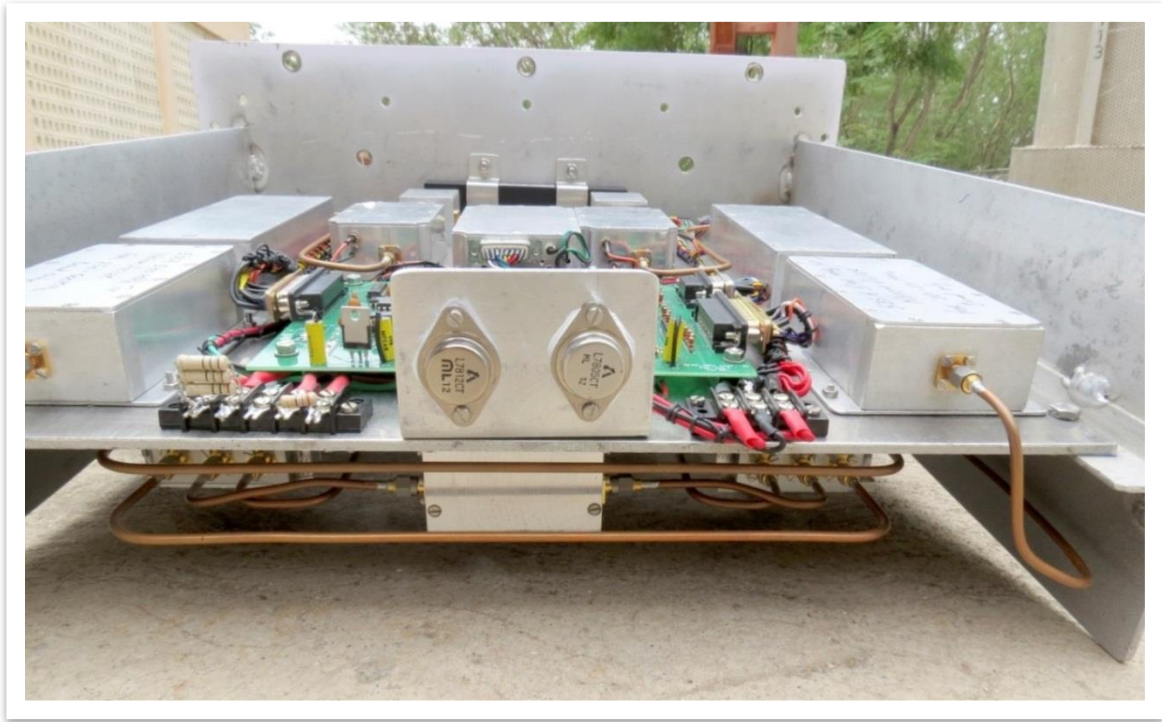

Figure54 (High Current Capacity TO-3 Voltage Regulators)

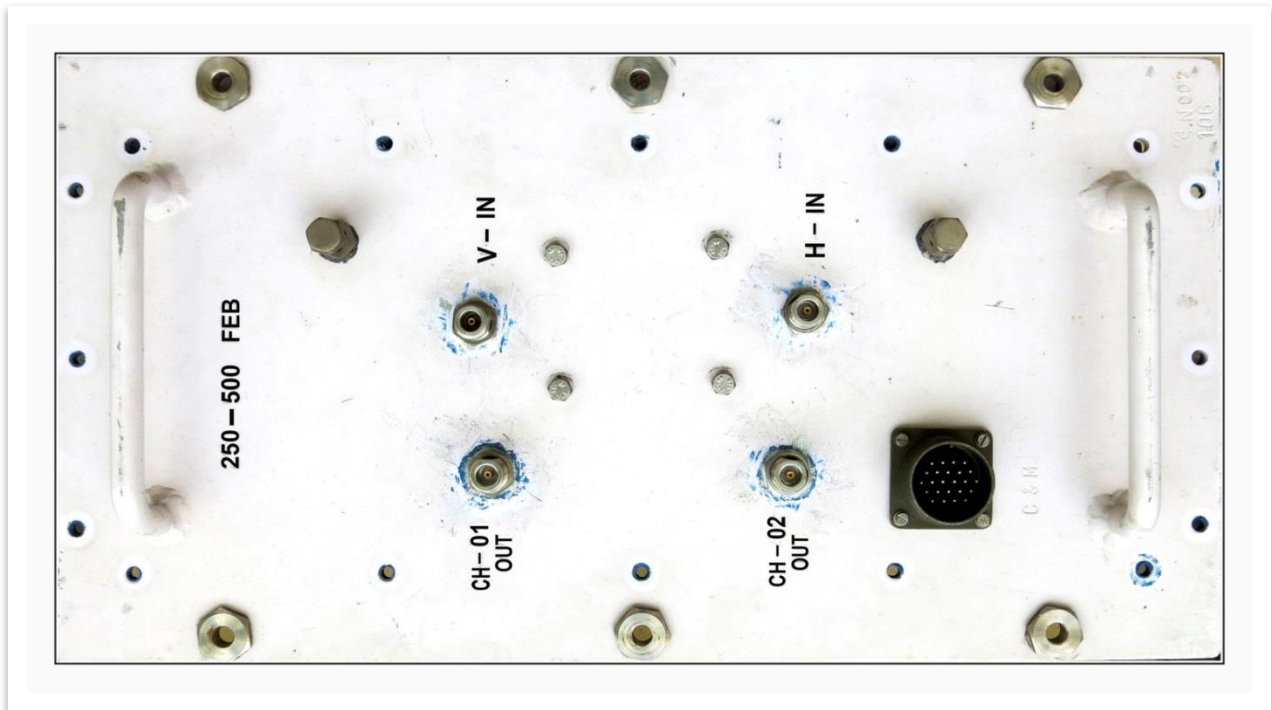

Figure 55 (Front View of 250-500 MHz FEB V.2)

15. WIRING DIAGRAM FOR RF SW6T SWITCH

Sr.No.	24 pin Round Shell Connector	26 pin FRC Connector (J5)	5 pin Terminal Strip	9 pin D-Type Connector for RF SW6T Chassis	Remark
1	F (Filter Select Bit) F0	9 (F0)	1 (White)	1 (Control – A)	Control Bit - A
2	G (Filter Select Bit) F1	10 (F1)	2 (Violet)	2 (Control – B)	Control Bit - B
3	H (Spare Bit)	11 (S)	3 (Yellow)	3 (Control – C)	Control Bit - C
4			4 (Red)	4 (VCC +5V)	VCC
5			5 (Black)	5 (GND)	GND

As there was no separate connector for filter selection in RFCM Card Ver.2 , we have taken filter selection bits from 26 pin FRC (J5) connector.

New Ver.3 of RFCM Card has provided separate 5 pin SIP (Jalex/Molex) connector for filter selection.

CONTROL SETTING IN FRONT END LAB

Sr.No.	RF Setting from FE LAB (Camand-15)	Antenna – C11 FE Box Ver.2
1	66	260-340 MHz
2	86	300-400 MHz
3	26	400-500 MHz
4	46	350-450 MHz
5	06	250-500 MHz

CONTROL SETTING FROM CONTROL ROOM

Sr.No.	RF Setting from Control Room	Antenna – C11 FE Box Ver.2
1	290	260-340 MHz
2	325	300-400 MHz
3	350	400-500 MHz
4	410	350-450 MHz
5	470	250-500 MHz

16. BILL OF MATERIAL FOR 250-500 MHz FRONT END BOX V-2

Sr.No.	Items	Quantity per antenna
1	Empty Front End Box	1
2	Al mounting plate	1
3	Al mounting plate for regulator (TO-3)	1
4	Al mounting plate for QH	1
5	QH (250-500 MHz) chassis	1
6	Directional Coupler (DC) complete chassis for ch-1	1
7	Directional Coupler (DC) complete chassis for ch-2	1
8	LNA 250-500 MHz complete chassis for ch-1	1
9	LNA 250-500 MHz complete chassis for ch-2	1
10	Noise generator complete chassis	1
11	BPF 250-500 MHz + notch 177 MHz complete chassis for ch-1	1
12	BPF 250-500 MHz + notch 177 MHz complete chassis for ch-2	1
13	Notch 540 MHz complete chassis for ch-1	1
14	Notch 540 MHz complete chassis for ch-2	1
15	6 to 1 RF Switch complete chassis	4
16	Sub-band (250-500 MHz) complete chassis	1
17	Phase Switch and Post Amplifier (250-500 MHz) for ch-1	1
18	Phase Switch and Post Amplifier (250-500 MHz) for ch-2	1
19	Front End Box Power Monitoring complete chassis for ch-1	1
20	Front End Box Power Monitoring complete chassis for ch-2	1
21	RFCM complete wired and tested card (PCB)	1
22	Temp. monitoring wired and tested card (PCB)	2
23	7812 TO-3 package	1
24	7805 TO-3 package	
25	5 pin terminal strip	1
26	3 pin terminal strip	2
27	Screw mounting tie support	20
28	Cable tie	20
29	SS Screws 3mm	125
30	SS Nuts 3 mm	125

SEMI-RIGID CABLES REQUIRMENT

Sr.No.	Description	Quantity per antenna
1	Noise generator to ch-1 LNA	1
2	Noise generator to ch-1 LNA	1
3	Ch-1 LNA output to ch-1 BPF input	1
4	Ch-1 LNA output to ch-1 BPF input	1
5	Ch-1 540 MHz notch output to 6 to 1 RF switch(S1) common input	1
6	Ch-2 540 MHz notch output to 6 to 1 RF switch (S2) common input	1
7	6 to 1 RF switch(S1) RF1 input to sub band Ch-1 input (1)	1
8	6 to 1 RF switch (S1) RF2 input to sub band Ch-1 input (2)	1
9	6 to 1 RF switch (S1) RF3 input to sub band Ch-1 input(3)	1
10	6 to 1 RF switch (S1) RF4 input to sub band Ch-1 input(4)	1
11	6 to 1 RF switch(S2) RF1 input to sub band Ch-2 input (1)	1
12	6 to 1 RF switch (S2) RF2 input to sub band Ch-2 input (2)	1
13	6 to 1 RF switch (S2) RF3 input to sub band Ch-2 input(3)	1
14	6 to 1 RF switch (S4) RF4 input to sub band Ch-2 input(4)	1
15	Sub band Ch-1 output (1) to 6 to 1 RF switch (S3) RF1 input	1
16	Sub band Ch-1 output (2) to 6 to 1 RF switch (S3) RF2 input	1
17	Sub band Ch-1 output (3) to 6 to 1 RF switch (S3) RF3 input	1
18	Sub band Ch-1 output (4) to 6 to 1 RF switch (S3) RF4 input	1
19	Sub band Ch-2 output (1) to 6 to 1 RF switch (S4) RF1 input	1
20	Sub band Ch-2 output (2) to 6 to 1 RF switch (S4) RF2 input	1
21	Sub band Ch-2 output (3) to 6 to 1 RF switch (S4) RF3 input	1
22	Sub band Ch-2 output (4) to 6 to 1 RF switch (S4) RF4 input	1
23	6 to1 RF switch (S1) RF5 input to 6 to 1 RF switch (S3) RF5 input	1
24	6 to1 RF switch (S2) RF5 input to 6 to 1 RF switch (S4) RF5 input	1
25	6 to1 RF switch (S3) common to Phase SW Amplifier input	1
26	6 to1 RF switch (S2) common to Phase SW Amplifier input	1
27	Ch-1 RF power monitoring output to FE box ch-1 output	1
28	Ch-2 RF power monitoring output to FE box ch-2 output	1

17. MECHANICAL DRAWINGS OF VARIOUS CHASSIS AND FE BOX

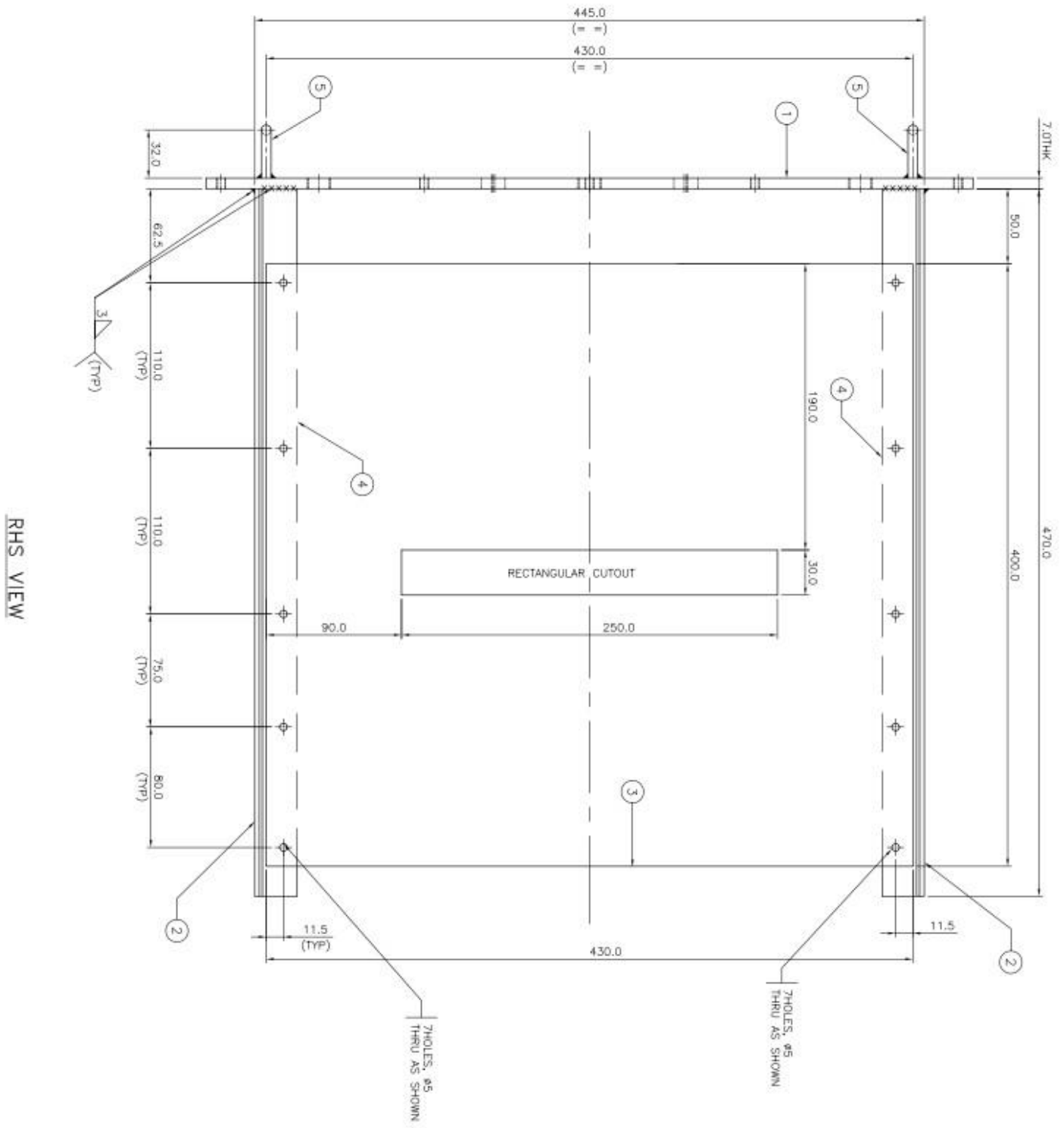

Figure 56 (TOP VIEW OF 250-500 MHz FRONT END BOX)

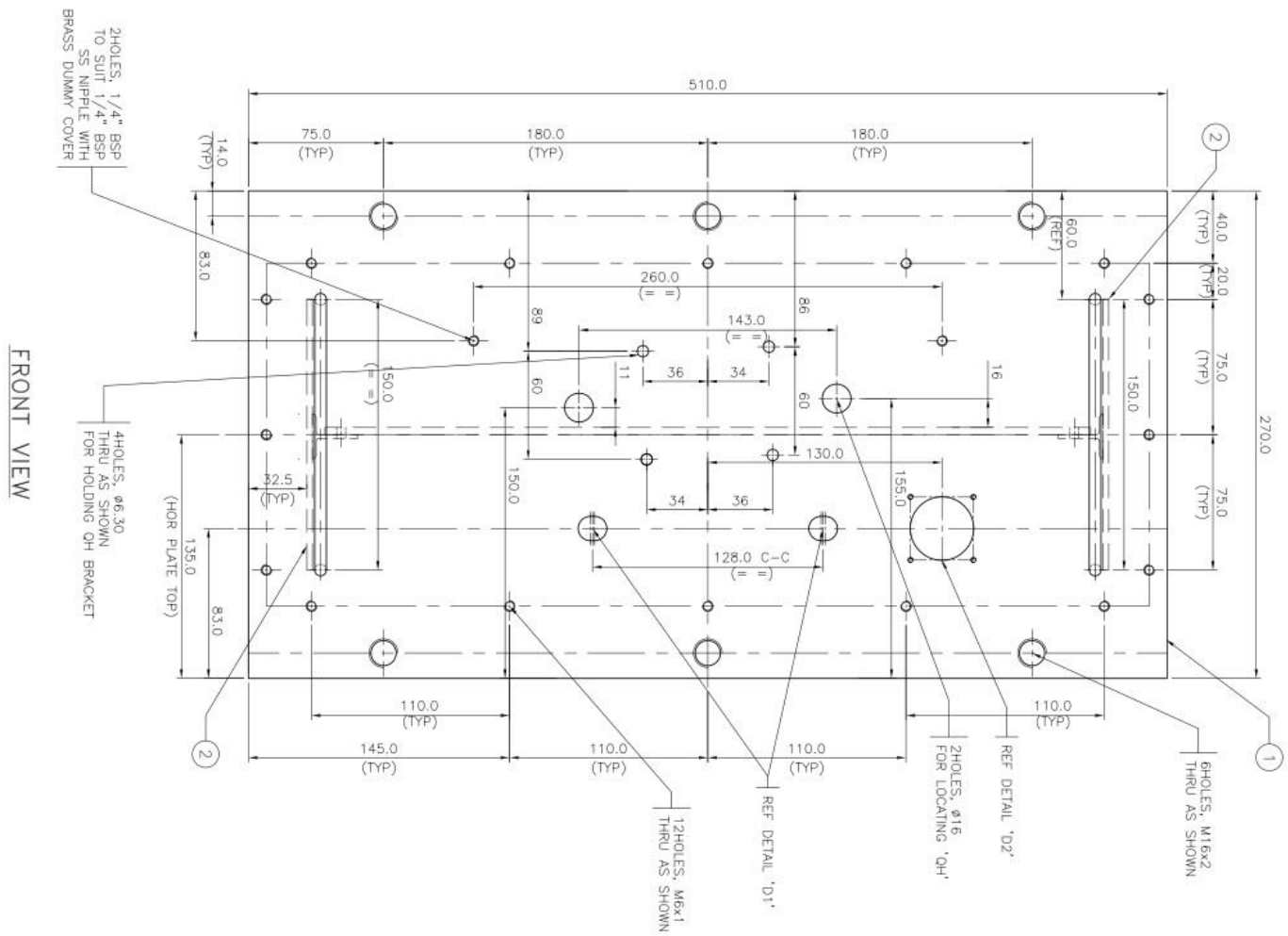

Figure 57 (FRONT VIEW OF 250-500 MHz FRONT END BOX)

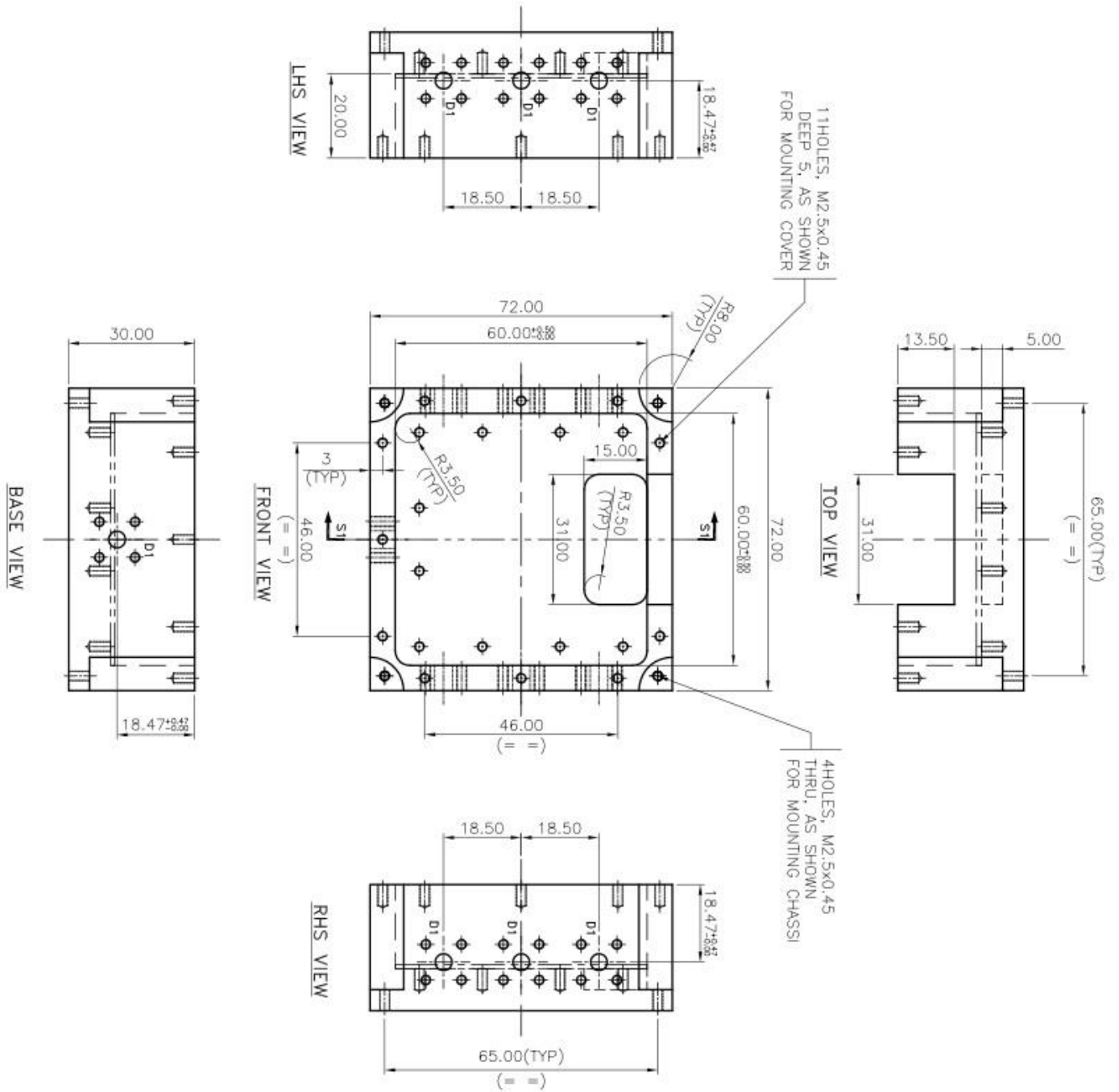

Figure 58 (RF SWITCH 6T1 CHASSIS)

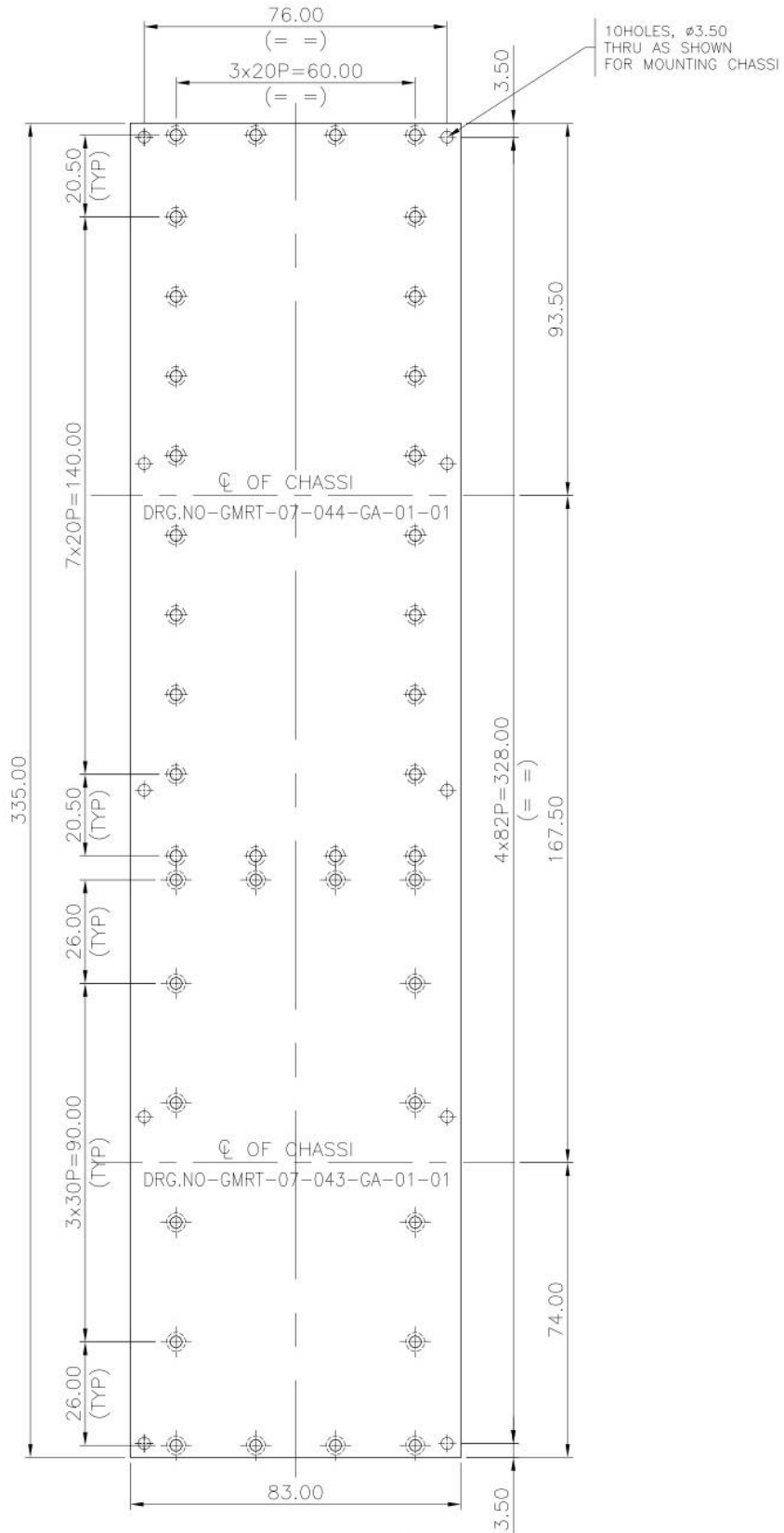

Figure 59 (SUB-BAND FILTER CHASSIS FOR CH-1 AND CH-2)

18. DATASHEET



HMC252QS24 / 252QS24E

GaAs MMIC SP6T NON-REFLECTIVE SWITCH, DC - 3 GHz

Typical Applications

The HMC252QS24 / HMC252QS24E is ideal for:

- Base Station
- CATV / DBS
- MMDS & WirelessLAN
- Test Equipment

Features

- Low Insertion Loss (2 GHz): 0.9 dB
- Single Positive Supply: $V_{DD} = +5V$ or $+3.3V$
- Integrated 3:6 TTL Decoder
- 24 Lead QSOP Package

Functional Diagram

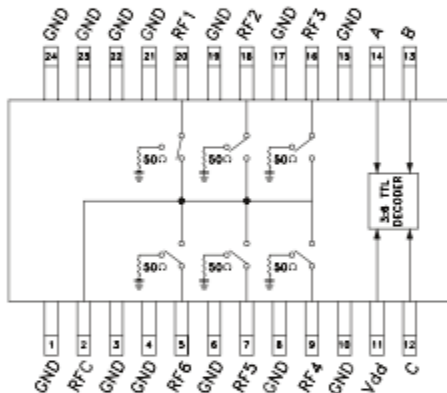

General Description

The HMC252QS24 & HMC252QS24E are low-cost non-reflective SP6T switches in 24-lead QSOP packages featuring wideband operation from DC to 3.0 GHz. The switch offers a single positive bias and true TTL/CMOS compatibility. A 3:6 decoder is integrated on the switch requiring only 3 control lines and a positive bias to select each path. The HMC252QS24 & HMC252QS24E SP6T replaces multiple configurations of SP4T and SPDT MMIC switches and logic drivers.

Electrical Specifications I,

$T_A = +25^\circ C$, For TTL Control and $V_{DD} = +5V$ in a 50 Ohm System

Parameter	Frequency	Min.	Typ.	Max.	Units
Insertion Loss	DC - 1.0 GHz		0.8	1.2	dB
	DC - 2.0 GHz		0.9	1.3	
	DC - 2.5 GHz		1.0	1.5	
	DC - 3.0 GHz		1.3	1.8	
Isolation	DC - 1.0 GHz	38	41		dB
	DC - 2.0 GHz	32	35		
	DC - 2.5 GHz	29	32		
	DC - 3.0 GHz	26	29		
Return Loss	DC - 2.5 GHz	14	18		dB
	DC - 3.0 GHz	7	12		
Return Loss	0.3 - 3.0 GHz	8	12		dB
	0.5 - 2.5 GHz	11	15		
Input Power for 1dB Compression	0.3 - 3.0 GHz	21	24		dBm
Input Third Order Intercept (Two-Tone Input Power = +7 dBm Each Tone)	0.3 - 3.0 GHz	42	46		dBm
Switching Characteristics	tRISE, tFALL (10/90% RF)		35		ns
	tON, tOFF (50% CTL to 10/90% RF)	0.3 - 3.0 GHz		120	

19. CONCLUSION.

Following are the various modifications done for 250–500 MHz Front End Box Ver.2

1. There are 8 nos. of chassis used for switching sub-band in Ver.1 (4 nos. for bypass mode and 4 nos. for sub-band mode)
2. There are only 4 nos. chassis used in Ver.2 for switching sub-band filters and for bypass mode.
3. There are 8 nos. of chassis used in Ver.1 for sub-band filter.
4. There is only one chassis used in Ver.2 for sub-band filter by combining all in single chassis and the PCB is mounted on both top and bottom sides .
5. In Ver.1 FE Box OLD RFCM card is used for different RF sub-band setting , data monitoring and additional patch card is used for Walsh switching.
6. In Ver.2 FE Box New RFCM card is used for different RF sub-band setting , data monitoring and Walsh switching without any additional patch card.
7. Physical size of Ver.1 FE Box is 620 X 445 mm and Ver.2 FE Box is 465 X 445 mm.
Weight of Ver.1 FE Box is 28 Kg and Ver.2 FE Box is 19 Kg.
8. Reduction of box size and weight is achieved by studying block diagram and implementing low loss , high isolation GT1 RF switch and double side chassis for sub-band filters and also utilizing proper available space for placing all the required chassis in the existing standard front end box.
9. New Noise Source PCBs has been design with small size as per specification.
10. Less the wiring, less is the problem.

20. REFERENCES.

1. 250 – 500 MHz Low Noise Amplifier for GMRT by Anil N. Raut
2. Broadband 300–500 MHz Front End System for GMRT by Aarti Kulkarni, Manisha Parate and V.B. Bhalerao.
3. Design of 250–500 MHz Switched filter bank for GMRT using Metamaterial ZOR Techniques by Sougata Chatterjee, Anil N Raut, S Suresh Kumar.
4. Complete signal flow analysis of 325 MHz frontend system by Gaurav Parikh & Anil Raut.
5. Raut, A., Bhalerao, V, A. Praveen Kumar,” Front–end Electronics for the upgraded GMRT “, IOP Conf. Series:Materials Science and Engineering 44 (2013) 012025 doi:10.1088/1757-899X/44/1/012025.