

# **Making of a pulsed noise source: Application to check temporal leakage in the GMRT signal chain.**

Navnath Shinde, Sweta Gupta, Ajay Vishwakarm, Ajit Kumar, Rahul Basu & Dipanjan Mitra

**National Center for Radio Astrophysics, Pune, India**

## **Abstract**

A broadband pulsed noise source was designed for calibration purpose for the GMRT. This report gives the technical details of the noise source that was built for this purpose. It also describes an experiment that has been carried out to test temporal leakage of the signal in the GMRT signal chain.

## **1 . Introduction**

Critical experiments in astronomy requires testing the radio telescope for several kinds of otherwise spurious signals. One such requirement is to be able to test the temporal leakage due to a strong pulsed source (like a pulsar). Very recently Basu et al. (2011) has discovered off-pulse emission from pulsars based on interferometric observations with the GMRT at 325 and 610 MHz which is a rather unique and new result. Basu et al. (2011) records the data from the correlator at 131 or 251 msec and uses the technique of offline gating followed by imaging to find the off-pulse emission. In this technique the main pulse emission is flagged and interferometric data only with the off region is calibrated and imaged. For this experiment one aspect that worried Basu et al. (2011) was if there were any temporal leakage of the signal introduced by the GMRT signal chain. In case such a leakage exist that could lead to spurious detection of the off-pulse emission. To investigate this they recorded front end terminated 131 milliseconds interferometric data (using GMRT hardware correlator) and estimated the auto correlation of this noise signal for each baseline. They found that the observed auto correlations were significantly lower (0.04%) than the required levels (around 1%) to explain the observed off-pulse emission purely due temporal leakages. However, the above experiment did not account for temporal leakages due to a strong pulsed signal as seen in pulsars. In order to investigate the temporal effects a set of narrow single pulses designed to have no off-pulse emission has to be introduced in the GMRT receiver system. In this report we describe the design specification of such a simulated noise source and describe the experiment that was done to test the temporal leakage in the GMRT signal chain.

## 2 . Making of a pulsed noise source

Based on requirement, we designed a Broad Band Pulsed Noise Source (BBPNS) plug in unit (PIU). The basic features of this unit are as follows:

- An attenuator controlled Broadband Noise Output from 20 MHz to 2 GHz.
- Two final power outputs: OUT-1 Port with default maximum Power of -1 dBm and OUT-2 port with default maximum Power of +17 dBm over a bandwidth of 2 GHz.
- A time based generator unit, used to make the output noise a pulsed noise source. The period and the on-pulse duty cycle of this noise source can be controlled by a CPLD based program. Currently the unit generates a period of 4sec with a duty cycle of 31.3 ms on time. The isolation between the On/ Off Period is about 35 dBm over the whole band.

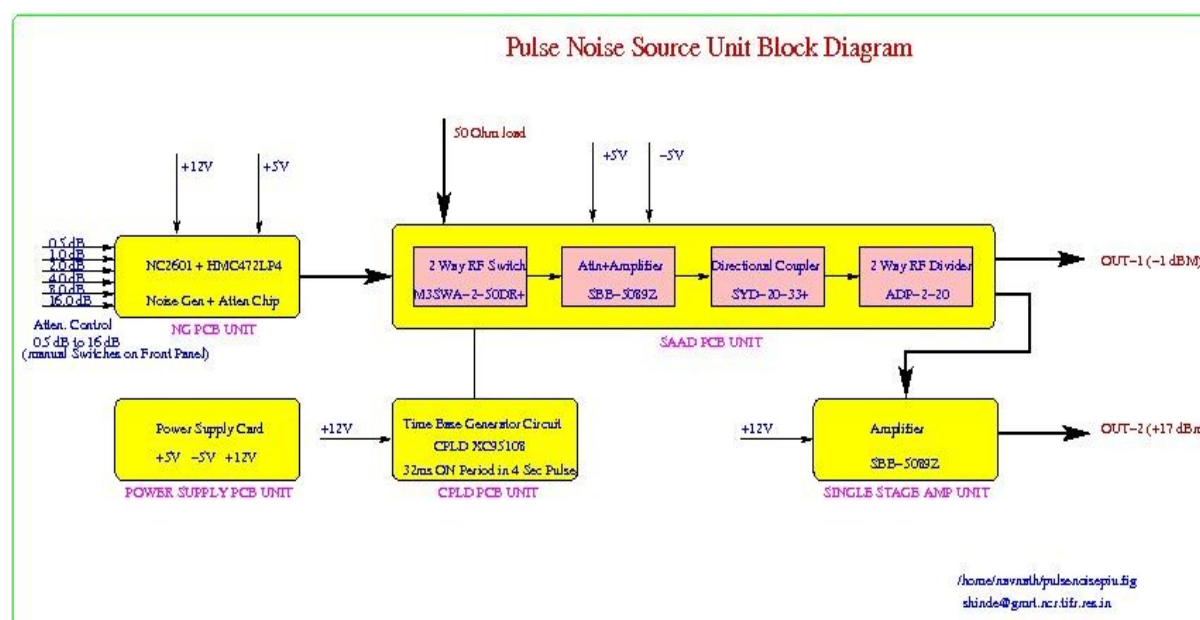

Figure 1: The schematic block diagram for the BBPNS

The schematic diagram for the BBPNS is shown in Fig. 1. Table 1 gives the output power levels for maximum and default settings of the various unit.

Name of Unit	Min RF Power Out (Max Attn 31.5 dB)	Max RF Power Out (default)	
NG PCB UNIT	-45.0 dBm	-13.66 dBm	
SAAD PCB UNIT	-32.5 dBm	-1.11 dBm	OUT-1 Port
SINGLE STAGE AMP UNIT	-14.5 dBm	+17.00 dBm	OUT-2 Port

Table 1: The table below gives the output power from various units of the BBPNS. The second column gives the minimum RF power out with maximum attenuation of the NG UNIT. The default output currently used is given in column 4.

Below we give technical details for NG PCB, SAAD and the CPLD PCB units as shown in the figure.

## 2.1 NG PCB: Design of Broadband noise source with a variable power level control as well as modulation of external signal with noise.

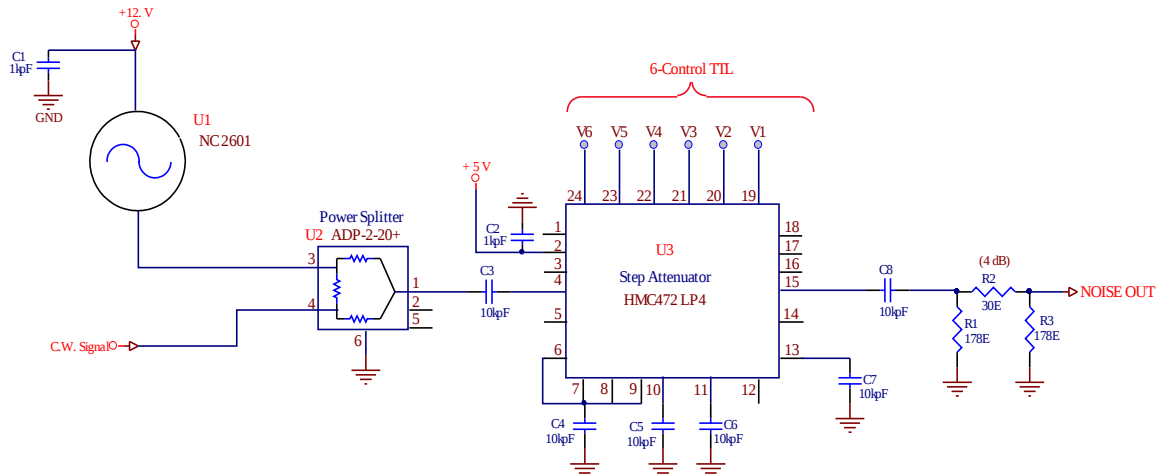
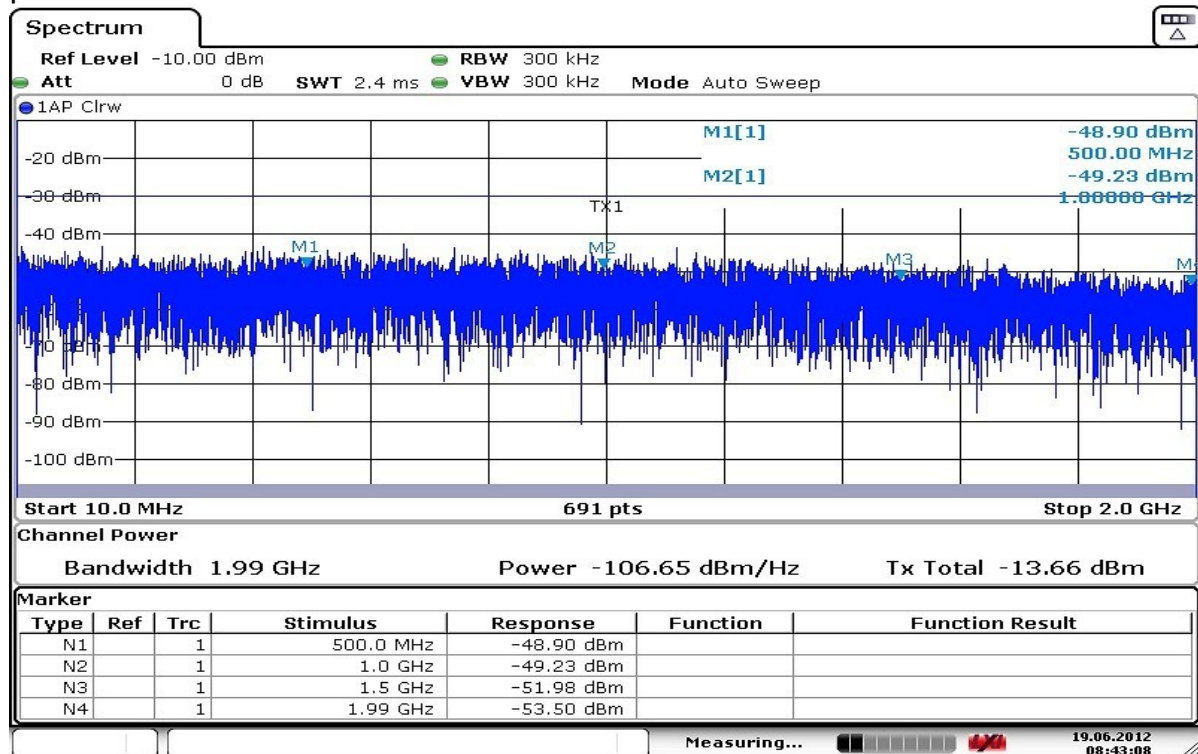

Figure 2: The schematic diagram for the NG PCB UNIT

The schematic for the NG PCB design is given in Fig. 2. The NOISECOM make MODEL NC2601 is broadband noise generator IC giving frequency in the range from 1 MHz – 2 GHz with -98 dBm/Hz power level ie -5 dBm power level with 2.0 dB flatness over the bandwidth. Fig. 3 shows the output power of the NG PCB UNIT over the whole band.



Date: 19.JUN.2012 08:43:09

Figure 3: The output of the NG PCB UNIT measured using a Spectrum analyzer.

The HMC472LP4 is a broadband 6-bit GaAs MMIC positive digital attenuators in lead less surface mount packages. This single positive control line per bit digital attenuator incorporates off chip AC ground capacitors for near DC operation, making it suitable for a wide variety of RF and IF applications. Covering DC to 3.8 GHz, the insertion loss is less than 2.0 dB typical. The attenuator bit values are 0.5 (LSB), 1, 2, 4, 8, and 16 dB for a total attenuation of 31.5 dB. Attenuation accuracy is excellent at  $\pm 0.25$  dB typical step error with an IIP3 of +45 dBm. Six TTL/ CMOS control inputs are used to select each attenuation state. A single Vdd bias of +5V is required.

The design of this PCB include a facility to add an additional noise source (for e.g. a CW wave) using a 2 way passive combiner of Mini circuit make ADP-2-20+ model. In the current setting this is terminated by 50 $\Omega$ . The attenuated noised signal (ANG) from the NG PCB goes into the SAAD PCB unit.

## 2.2 SAAD PCB: Design of Switch, Attenuator, Amplifier, divider as well as monitoring Port.

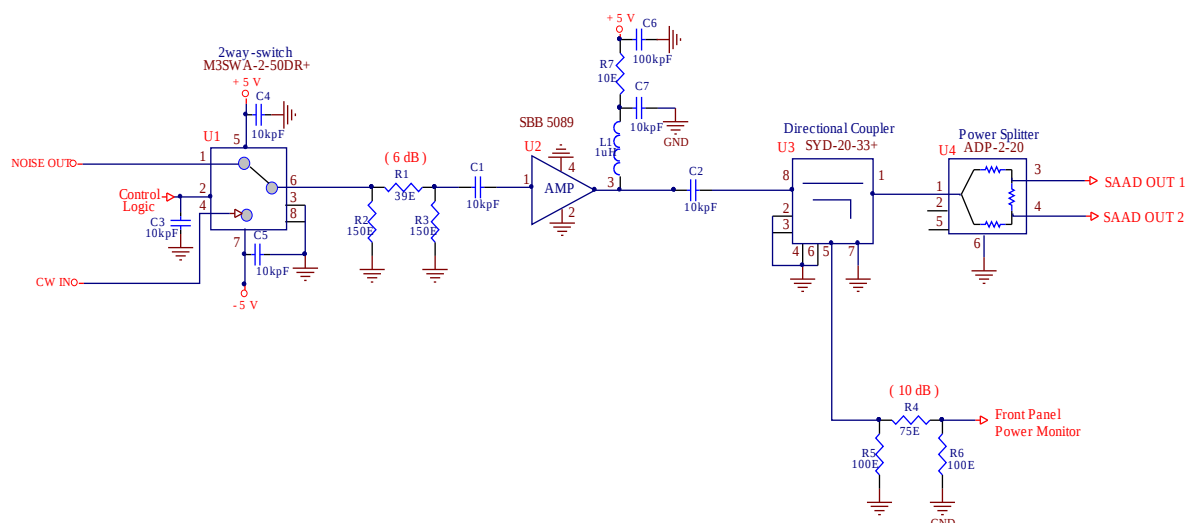
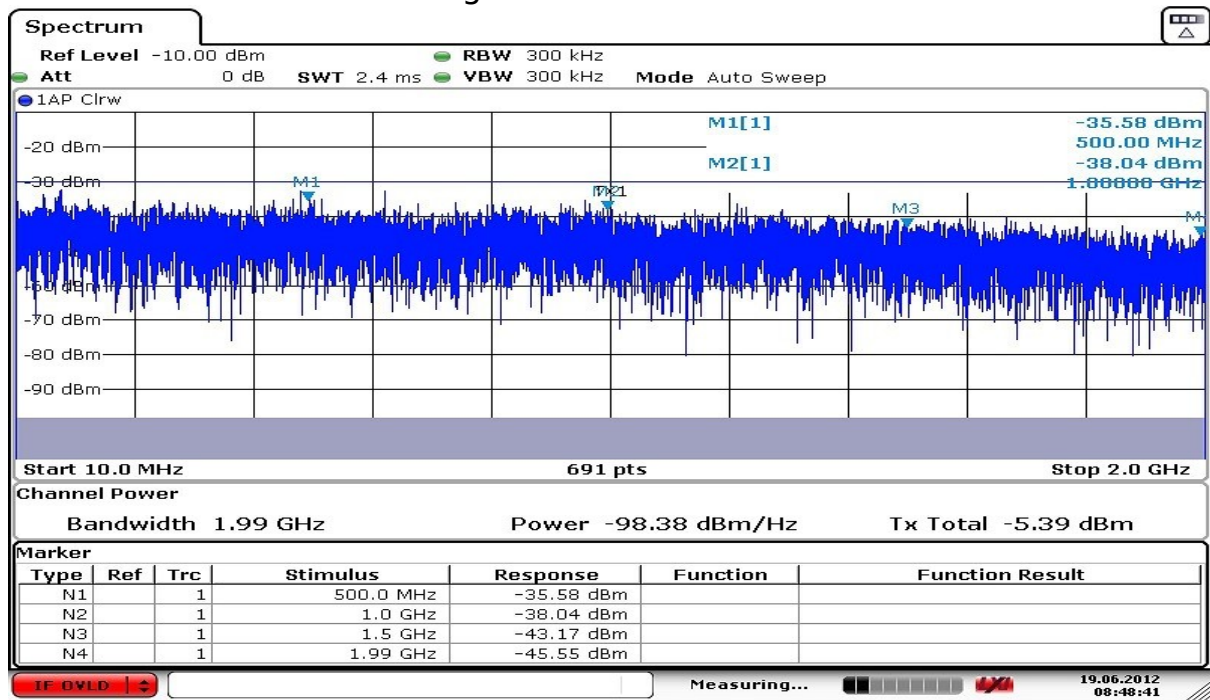

Figure 4: The schematic diagram for the SAAD PCB UNIT

The input ANG, which has a default value of -13.3 dBm (see Table. 1), is given as an input to the SAAD unit. The continuous noise signal is first switched which is controlled by a time based generator card (discussed in the next section), and a pulsed output is generated with typical isolation of 35 dBm (over the whole band of 2 MHz to 2 GHz) between the On and Off region. The pulsed signal is further amplified to meet the output power level requirement of +17 dBm. A directional coupler provides 20 db down power to a monitoring port. Finally the 2 way divider (giving two copies of the output) and attenuator are used to maintain the output power level. The schematic for this unit is given in Fig. 4.

The Mini circuit make IC M3SWA-2-50DR+ is a 50  $\Omega$  single pole double throw (SPDT) with Absorptive DC to 4500 MHz surface mount high isolation switch of 65 dB at 1GHz, having low insertion loss of 0.7dB. The output of the SAAD PCB Unit is shown in Fig. 5.



Date: 19.JUN.2012 08:48:41

Figure 5: The output of the SAAD PCB UNIT measured using a Spectrum analyser.

## 2.3 . Single stage Amplifier Unit.

One of the output from the SAAD needs to be amplified to give the desired output level of +17 dBm. This is done using the single stage amplifier unit. The feature of this unit are:

- 1) It has a Gain of 18 dbm
- 2) Has 1 dB compression point at +19 dBm.
- 3) Has a Flatness of 2 dB over Dc to 2 GHz bandwidth.

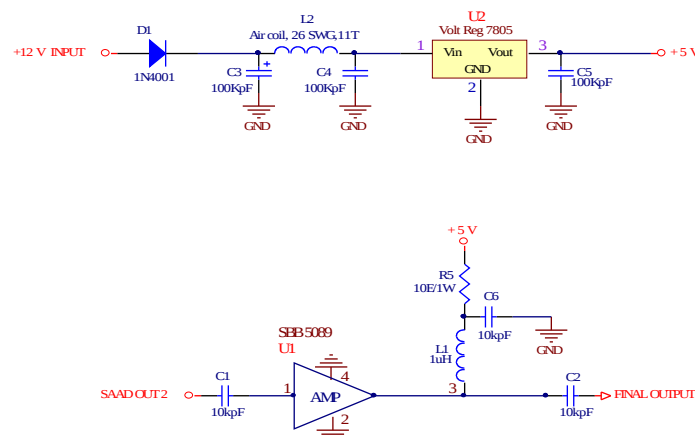
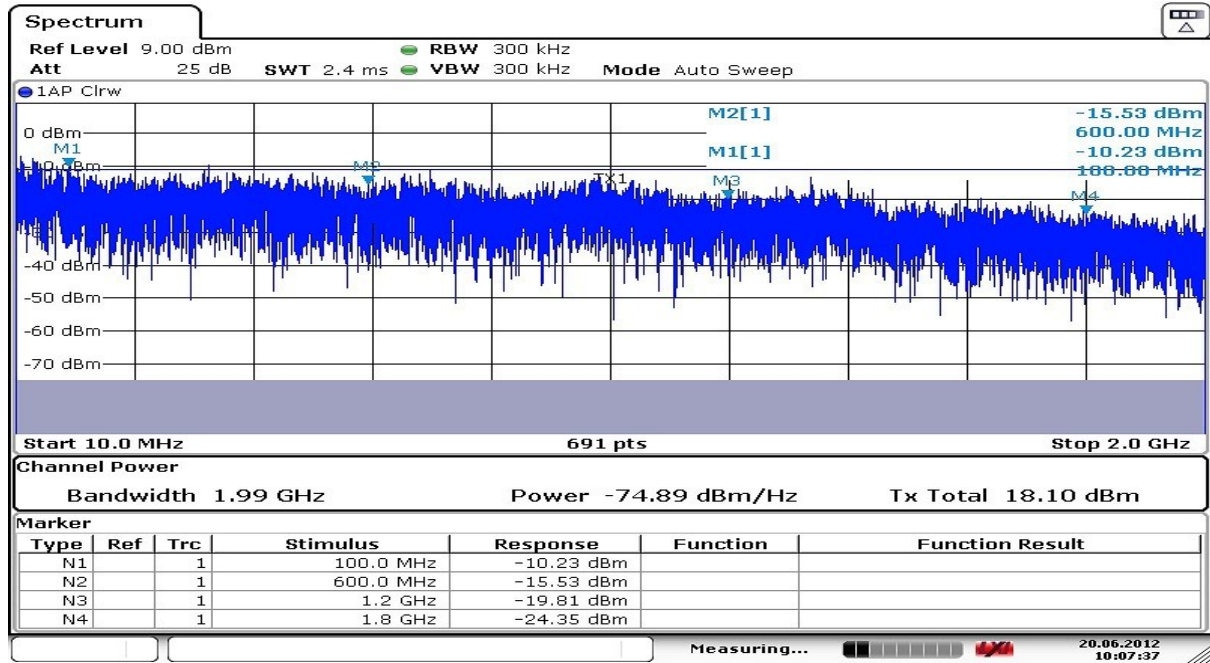

Figure 6: The schematic diagram for Single Stage Amplifier unit

The schematic diagram for this unit is given in Fig. 6. The RFMD make SBA-5089Z is DC to 5GHz, CASCADABLE InGaP/GaAs HBT MMIC AMPLIFIER available in Package: SOT-89. This amplifier offer a gain of 18 dBm and 1 dB compression point +19 dBm with a flatness of 2dB over a bandwidth of 2 GHz. The final output signal measured at the OUT-2 port without switching is shown in Fig. 7.



Date: 20.JUN.2012 10:07:37

Figure 7: The final output at OUT-2 port without switching.

## 2.4. Design of Time Base Generator Unit

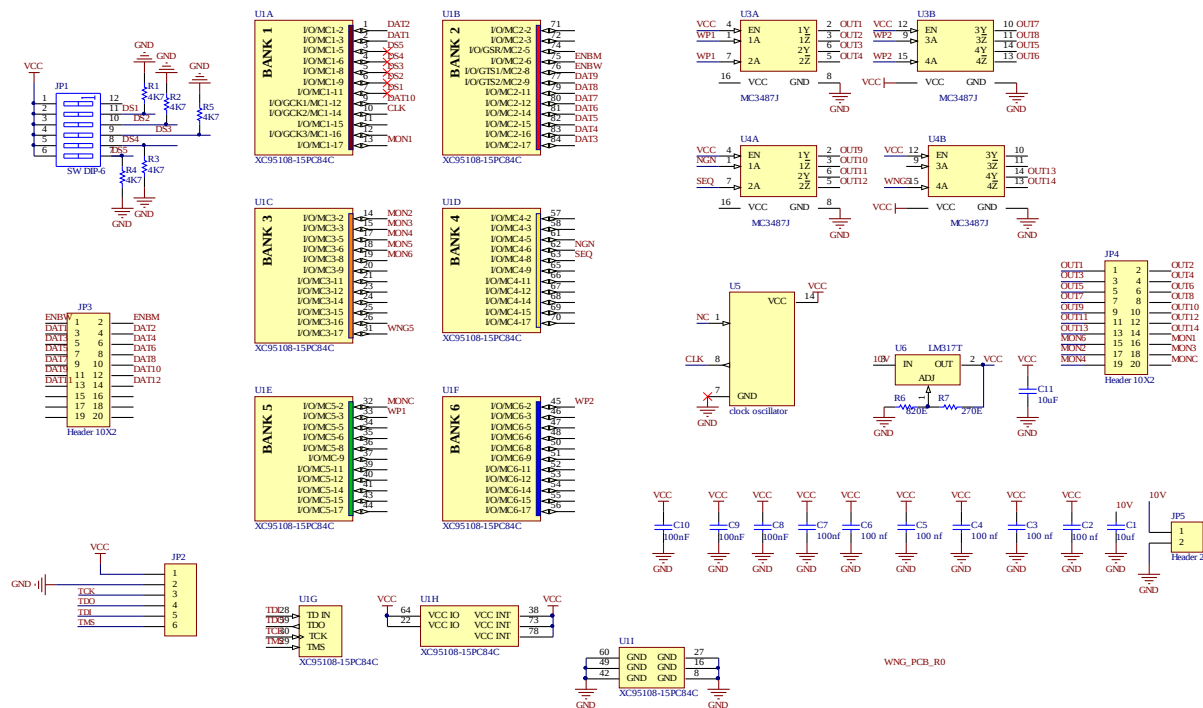

Figure 8: Schematic Diagram of CPLD control (XC95108-15PC84) Unit used in the Time Base Generator Unit. The crystal value used is 1.048576 Mhz

This unit generates a Pulse sequence of a certain period and duty cycle. The unit currently gives a period of 4 sec with duty cycle of 31.3 msec. A clock crystal of 1.048576 MHz is used as a clock source to the complex programmable logic device (CPLD). CPLD program is written in such a way that it divides this clock by 221 i.e. ( 2097152) to give a correct pulse sequence period of 4 sec. The On period of pulsed achieved 31.3 ms by dividing the clock by  $2^{14}$  ie (16384) .

By changing the CPLD program different combination of period and on time period can be achieved.

The Design uses Xilinx make XC95108-15PC84 CPLD, a CPLD with 84 pin PLCC base and 15 ns pin to pin propagation delay time. It had 108 macro cells with 2400 usable gates. The schematic diagram for the CPLD control (XC95108-15PC84) Unit is shown in Fig. 8. Crystal value used is 1.048576 MHz.

A clock Crystal Oscillator (CXO-100 series TTL) of Andhra Electronics is used for frequency 1.048576 Mhz having stability of  $\pm 25$  PPM and TTL out. The final time series output of the BBPNS is a sequence of pulses and a single pulse is shown in Fig. 9. The waveform was further averaged in the oscilloscope to get various measurement as shown in Fig. 10. The following pulse properties were measured.

ON TIME = M3-M2 = 43.3333 - 12.2464 = 31.0869 msec  
 Total Period = M4-M1 = 43.5507-12 = 31.5507 msec  
 Rise Time = M2-M1 = 12.2464-12 = 0.2464 msec  
 Fall Time = M4-M3 = 43.5507 - 43.3333 = 0.2174 msec

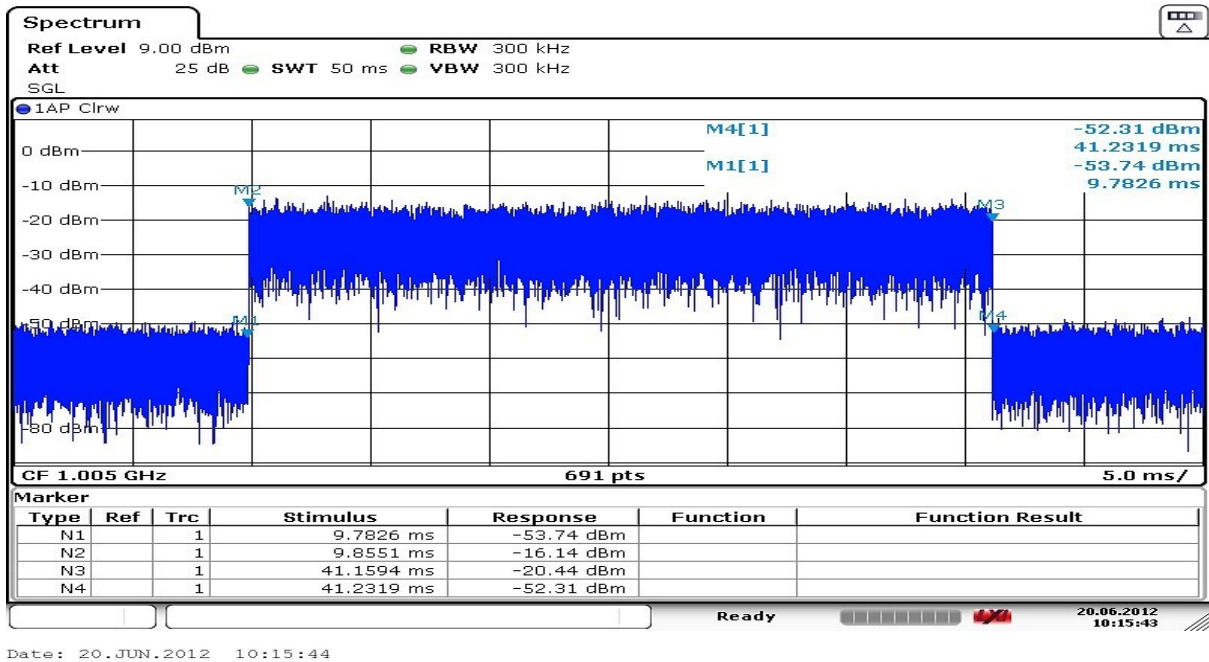

Figure 9: The output of the pulsed BBPNS measured by spectrum Analyzer at OUT-2 port.

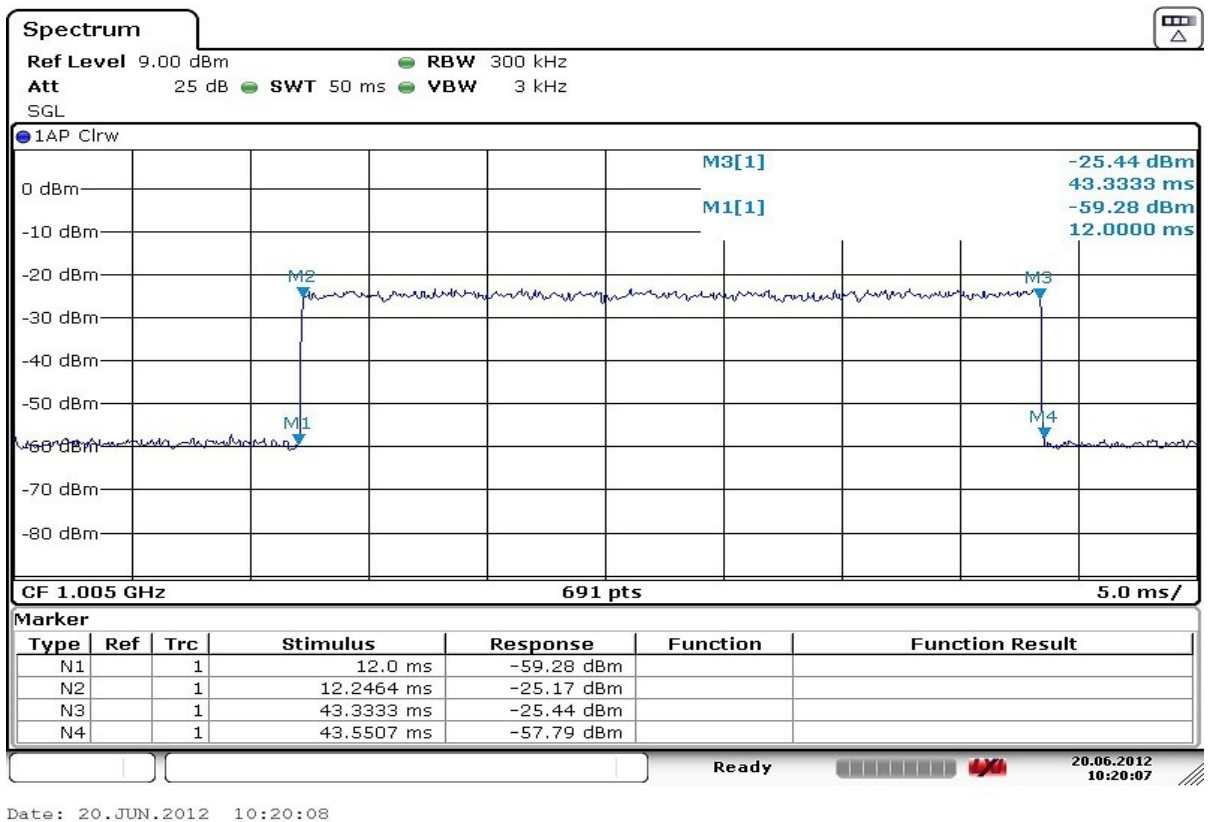

Figure 10: The output of the pulsed BBPNS at OUT-2 port averaged in time to measure the pulse properties (see text for details).



**Table 2: Bill of materials for NGN + VAR. ATtn. Unit**

BILL OF MATERIALS FOR NGN + Var. Attn.					
SR No.	Description	Type / Make	Designator	Value	Quantity
1	Capacitor	SMD	C3, C4, C5, C6, C7,C8	10kpF	6
		SMD	C1,C2	1kpF	2
2	Resistor	SMD	R2	30E	1
		SMD	R1, R3	178E	2
3	Noise Source	Module	U1	NC 2601(2GHz)	1
4	Power Splitter	MCL	U2	ADP-2-20+	1
5	Step Attenuator	Hittite	U3	HMC472LP4	1

**Table 3: Bill of materials for SAAD unit**

BILL OF MATERIALS FOR SAAD					
SR No.	Description	Type / Make	Designator	Value	Quantity
1	Capacitor	SMD	C1, C2, C3, C4, C5	10kpF	5
		Ceramic	C7	10kpF	1
		Ceramic	C6	100kpF	1
2	Inductor	Moulded	L1	1uH	1
3	Resistor	CFR	R1	39E, 1/4W	1
		CFR	R7	10E, 1W	1
		CFR	R4,	75E,1/4W	1
		CFR	R5, R6,	100E,1/4W	2
		CFR	R2, R3,	150E,1/4W	2
4	2 Way-switch	MCL	U1	M3SWA-2-50DR	1
5	RF Amplifier	Sirenza	U2	SBB 5089Z	1
6	Directional Coupler	MCL	U3	SYD-20-33+	1
7	Power Splitter	MCL	U4	ADP-2-20	1

**Table 4 : Bill of materials for Amplifier (SBA5089Z)**

BILL OF MATERIALS FOR SIRENZA AMPLIFIER (SBA 5089Z)					
SR No.	Description	Type / Make	Designator	Value	Quantity
1	Capacitor	SMD	C1, C2, C6	10kpF	3
		Ceramic	C3, C4, C5	100kpF	3
2	Inductor	Moulded	L1	1uH	1
			L2	Air coil, 26 SWG,11T	1
3	Resistor	CFR	R5	10E, 1W	1
4	Diode		D1	IN 4001	1
5	RF Amplifier	Sirenza	U1	SBB 5089 Z	1
6	Voltage Regulator		U2	7805	1

## 2.5 Photos of the BBPNS

The bill of materials for the various units are given in Table 2, 3 and 4.

Fig 11 shows the top view of the BBPNS, front panel and the experimental setup respectively.

Snapshot of PIU :

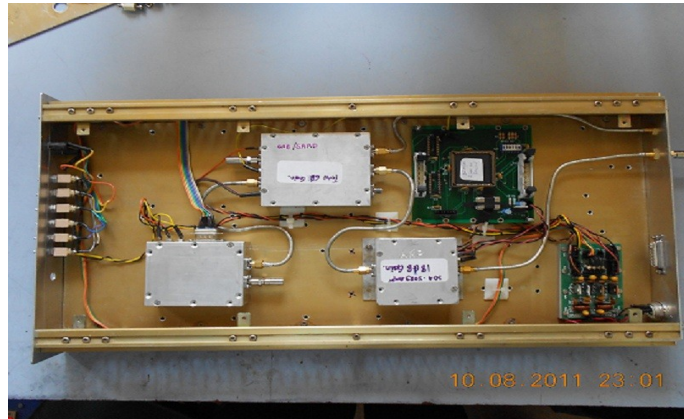

Snapshot of PIU Front Panel :



Snapshot of PIU under Test :

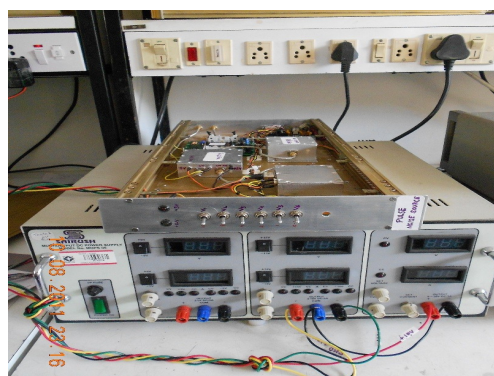

Figure 11 Photos of BBPNS.

### **3 . Pulsed Noise Source : Testing the smearing of signal across time.**

Our aim is to quantify temporal leakages (if any) in the GMRT signal chain due to a strong pulsed signal generated by the noise source discussed in the previous section. For our experiment (also reported in Basu et al. 2012) we used the mode of the noise source with period 4 second and a duty cycle of 31.0869 millisecond. The output power of the on pulse signal is -1 dBm and the signal is down by 30 db when off. We connected the noise source to an monopole antenna and radiated from the top of a building in the central square of the GMRT. We recorded data in both the high time resolution pulsar mode and Interferometric mode. The experiment was done at 610 MHz.

During the experiment all the antennas used were rotated towards the central building. The data was recorded in the pulsar phased array mode option of the GMRT software correlator (GSB) by adding signals from C02, C03, C04, C06 and C08. Note that although the phased array mode was used no phasing using an astronomical source is necessary. The data was recorded with a time resolution of 491.52 microseconds. The time series of the recorded data is shown in Fig 12. The folded profile of the noise source is shown in Fig. 13. The data when folded with a periodicity of 4 seconds had the width of the pulse as 35.65 millisecond at 10% of the peak value and 31.18 millisecond at 50% of the peak value. We checked for stability of the pulse features over time and found that the noise source was stable enough for carrying out our interferometric analysis for determination of leakage.

Interferometric data was recorded using the GSB high time resolution of 251 milliseconds for about half an hour with the noise source switched on. Since the noise source was in the near field, the geometrical delay calculations were vastly complicated (it is a function of the distance of the individual antennas from the pulsed noise source). Hence we did not correct for any geometrical delay in the correlator chain by using the facility of correcting fringe stop for the north pole. This implied that only for a handful of cases (10 baselines) the antennas were close enough for the coherence condition to hold and these baselines were used for the subsequent analysis as discussed below. These 10 base lines were C02-C03, C02-C04, C02-C06, C02-C08, C03-C04, C03-C06, C03-C08, C04-C06, C04-C08 and C06-C08.

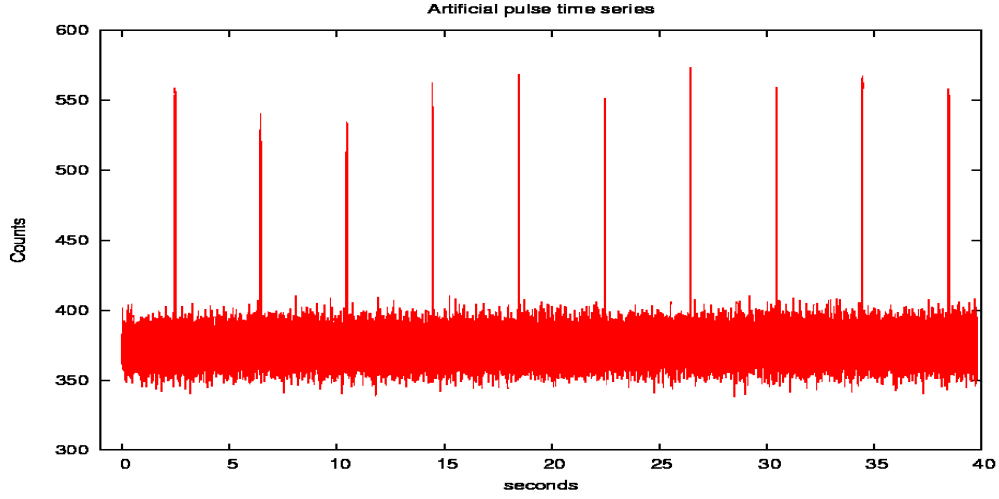

Figure 12: The time series of the BBPNS as recorded by the pulsar phased array mode of the GSB. The period is 4 sec.

Let us first note that if there was no leakage of the simulated pulsed signal in time, then on folding the pulsar data for any baseline the off-pulse noise and in turn the signal to noise would increase as the  $\sqrt{N}$  where  $N$  is the number of folded pulses. Now let us look at the case where there is temporal leakage of the signal. The interferometer measures the correlation between the voltages recorded by the individual elements (Thompson et al. 1986).

$$r(\tau) = \frac{1}{2T} \int_{-T}^T V1(t) \times V2(t - \tau) dt \quad (1)$$

where the quantity  $r(\tau)$  is related to the intensity of the incident signal and  $2T$  is the temporal resolution (251 msec). We assume that the system introduces a constant fractional leakage into the adjacent time bin (this is the most likely situation, besides any other situation will lead to a lower SNR) for each antenna. The correlation in the adjacent bin next to the pulsed signal in such a scenario is given as:

$$r'(\tau) = \epsilon^2 \frac{1}{2T} \int_{-T}^T V1(t) \times V2(t - \tau) dt, \epsilon < 1 \quad (2)$$

The correlation in the next bin would be  $\epsilon^2 \times r'(\tau)$  and so on. The statistics of the bins adjacent to the pulse (the whole off-pulse region) is characterized by a geometric series with mean ( $\mu$ ) and rms ( $\sigma$ ) given as:

$$\mu = \epsilon^{2n} \frac{(1 - \epsilon^{2N})}{N(1 - \epsilon^2)} \times r(\tau) \quad (3)$$

$$\sigma \sim \frac{\epsilon^{2n}}{(1-\epsilon^2)} \sqrt{\frac{1}{N} \frac{(1-\epsilon^{2N})}{N(1-\epsilon^2)}} x r(\tau) \quad (4)$$

Here the first bin is the  $n$ th bin from the pulsed source with  $N$  bins used for statistics;  $r(\tau)$  is the correlation in the pulsed source bin. In such a situation the statistics of the adjacent bins will be governed by a combination of Gaussian statistics due to random noise and the constant leakage into adjacent bins. However for sufficient long averaging the effect of random noise will be overshadowed by the leakage term and the SNR for the pulsed source would saturate at a constant value.

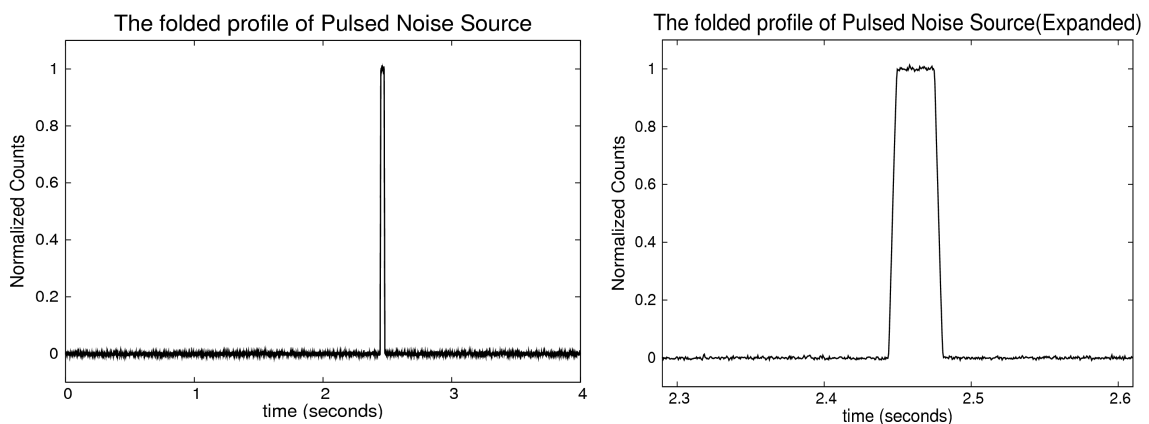

Figure 13: The pulsed noise source as observed in the pulsar mode with a time resolution of 491.52 microsecond. The left plot shows the full period and the right plot is a zoomed in version. The periodicity is 4 sec with the width of the pulse as 35.65 millisecond at 10% of peak value and 31.18 millisecond at 50% of peak value.

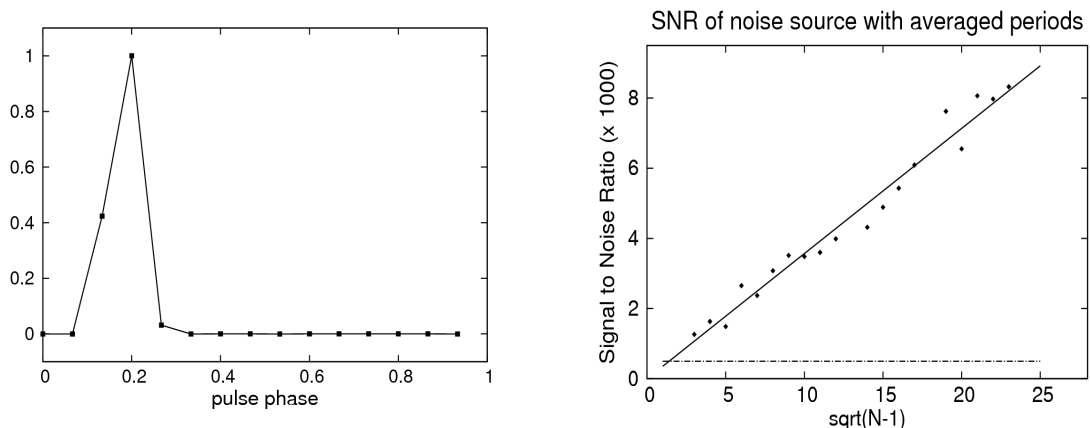

Figure 14: The pulsed noise source as observed with the interferometer (left), with 565 folded periods of 4 sec. The right panel gives the signal to noise ratio for different number of folds. The points are the measurement and the solid line is the  $\sqrt{N}$  line (where  $N$  is the number of periods folded) which is in good agreement with the data. The dashed line correspond to the expected level of saturation if the leakage were to explain the off-pulse emission (see text for details).

The interferometric data from the pulsed noise source so recorded with the GMRT correlator system were folded with the periodicity of pulsed noise source (4 seconds), to determine the profile (see Fig. 13). A large number of profiles of the noise source were generated by folding an increasing number of periods. The SNR for each of these profiles were calculated, by dividing the total signal in the noise bin with the rms fluctuation in the adjacent bins. In Fig. 14 we plot the SNR as a function of the square root of the number of periods (points) along with the best fit (dark solid line).

Basu et al. (2011) have detected off-pulse emission in the pulsars which is at a level of 0.5 – 1 % of the On-pulse flux. The Off-pulse region in our studies are 5 bins ( $n$ ) from the On-pulse and we can calculate the leakage ( $\epsilon$ ) required using equation 3 and 4 to explain the detected off-pulse. This would lead to a SNR of  $\sim 500$  as represented by the dashed horizontal line in Fig. 14. However the bins adjacent to the noise source continue to follow Gaussian statistics upto SNR  $\sim 8000$  as seen in figure 15. This implies that the temporal leakage can only lead to a off-pulse emission which is less than 0.03 % of the On-pulse flux in the off-phase. Hence the detected off-pulse emission cannot originate as a result of temporal leakage of the On-pulse signal into adjacent time bins.

## 4 . Distribution of Work

- Project Assignment and Specification: Dipanjan Mitra, Shri. Ajit Kumar.
- Project Design (circuit Designer): Mr. Navnath shinde, Engineer
- Timing Generator (CPLD Programming): Ms. Sweta Gupta, Engineer
- PIU wiring, Hot and cold testing: Mr. Ajay Vishwakarm
- Integrated Unit testing: Mr. Navnath Shinde and Ms. Sweta Gupta
- Testing the GMRT system: Rahul Basu, Dipanjan Mitra

**Acknowledgement:** We thank Ramana Athreya for discussions motivating the possibility of testing the temporal leakage in the GMRT system using a pulsed noise source.

### References:

Basu, R., Athreya, R., Mitra D. 2011, ApJ , 728, 157  
Basu, R, Mitra, D, Athreya, R, 2012, accepted for publication in Apj  
Thomson, A.R., Moran, J.M., Swenson G.W. 1986, Interferometry and Synthesis in Radio Astronomy (Wiley Interscience, New York).